

MAIN CRANE - GROVE GMK 7550	
BOOM LENGTH	115.9 FT
JIB LENGTH	N/A
BASE	100% OUTRIGGERS
COUNTERWEIGHT	264,500 LBS
MAX RADIUS	35 FT
CAPACITY AT MAX RADIUS	282,000 LBS
LOADS	
BLOCK	3,970 LBS
RIGGING	706 LBS
100% OF LOAD	210,110 LBS
TOTAL LOAD	214,786 LBS
% OF CAPACITY	76.2%
TAIL CRANE - GROVE GMK 5275	
BOOM LENGTH	89.3 FT
JIB LENGTH	N/A
BASE	100% OUTRIGGERS
COUNTERWEIGHT	169,700 LBS
MAX RADIUS	30 FT
CAPACITY AT MAX RADIUS	155,000 LBS
STOWED JIB DEDUCT	1,215 LBS
NET CAPACITY AT MAX RADIUS	153,785 LBS
LOADS	
BLOCK	3,640 LBS
RIGGING	178 LBS
100% OF LOAD	98,880 LBS
TOTAL LOAD	102,698 LBS
% OF CAPACITY	66.8%

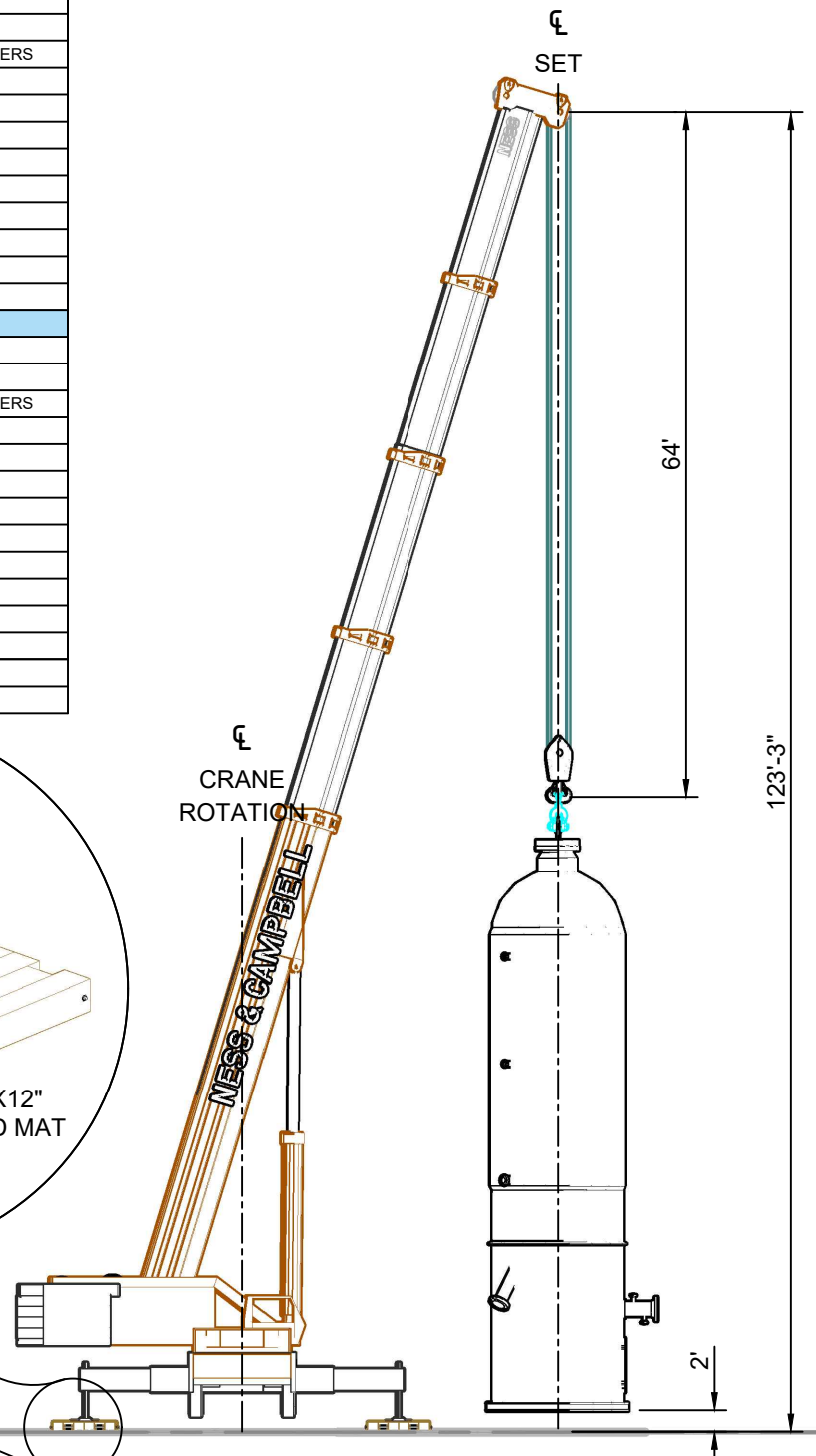

**ELEVATION VIEW**  
LOOKING SOUTH

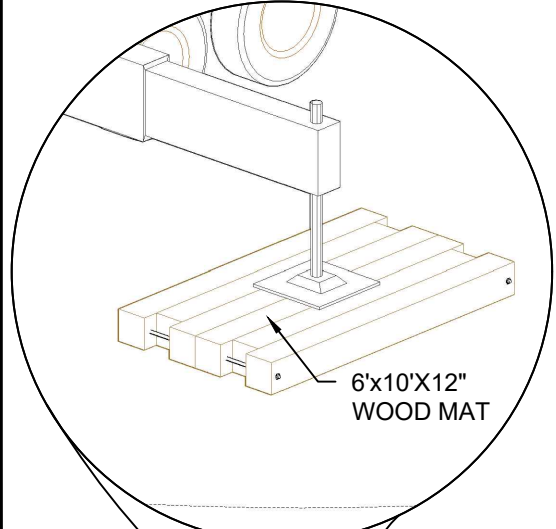
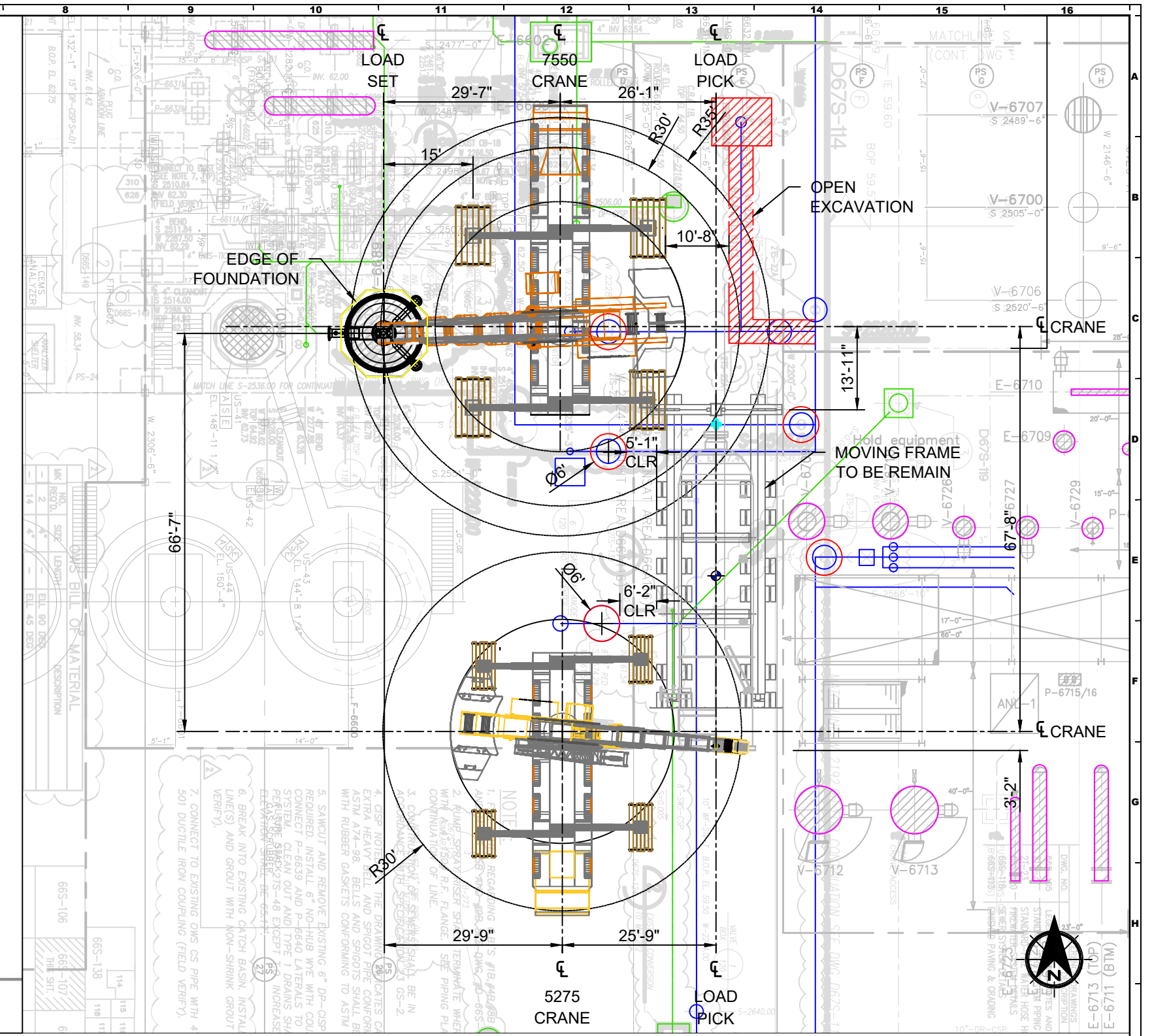

**PLAN VIEW**

**GENERAL NOTES:**  
 1. LOAD WEIGHT AND LOAD CENTER PROVIDED BY CUSTOMER.  
 2. EXISTING SUPPORT SURFACE TO BE VERIFIED BY OTHERS. MAXIMUM OUTRIGGER LOADS AVAILABLE UPON REQUEST.

REV #	REVISIONS	DATE	REV BY	CHK BY



**OFFICES:**  
 SEATTLE DIVISION - 1821 180TH ST S.E. BOTHELL, WA 98031 (206) 784-1054  
 PORTLAND DIVISION - 5730 NE 138TH AVE PORTLAND, OR 97320 (503) 283-3111

**DISCLOSURE:**  
 THIS DOCUMENT IS THE PROPERTY OF NESS & CAMPBELL CRANE, INC. THIS DOCUMENT SHALL NOT BE REPRODUCED, COPIED, DISCLOSED TO OTHERS, OR USED FOR ANY PURPOSE OTHER THAN THAT FOR WHICH IT WAS FURNISHED WITHOUT PRIOR WRITTEN CONSENT OF NESS & CAMPBELL CRANE, INC.

**TITLE:** V-6689 NHT REACTOR ERECTION  
**PROJECT:** CPUP, ANACORTES, WA.  
**CUSTOMER:** TESORO REFINING AND MARKETING CO.  
**DESCRIPTION:** SITE LAYOUT

**DATE:** 11/1/2016  
**DRAWN BY:** M.A.  
**APPROVED BY:** M.A.  
**SCALE:** AS SHOWN  
**SHEET:** 1 OF 2

MAIN CRANE - RIGGING WEIGHTS			
COMPONENT	QTY	WEIGHT	TOTAL WEIGHT
VAN BEEST P-6036 150t SHACKLE	2	353#/EA	706
TOTAL			706

TAIL CRANE - RIGGING WEIGHTS			
COMPONENT	QTY	WEIGHT	TOTAL WEIGHT
SKOOKUM NO. 263 82T SHACKLE	1	85#/EA	85
OSP 30' OL10 POLYESTER ROUND SLING	1	3.1#/FT	93
TOTAL			178

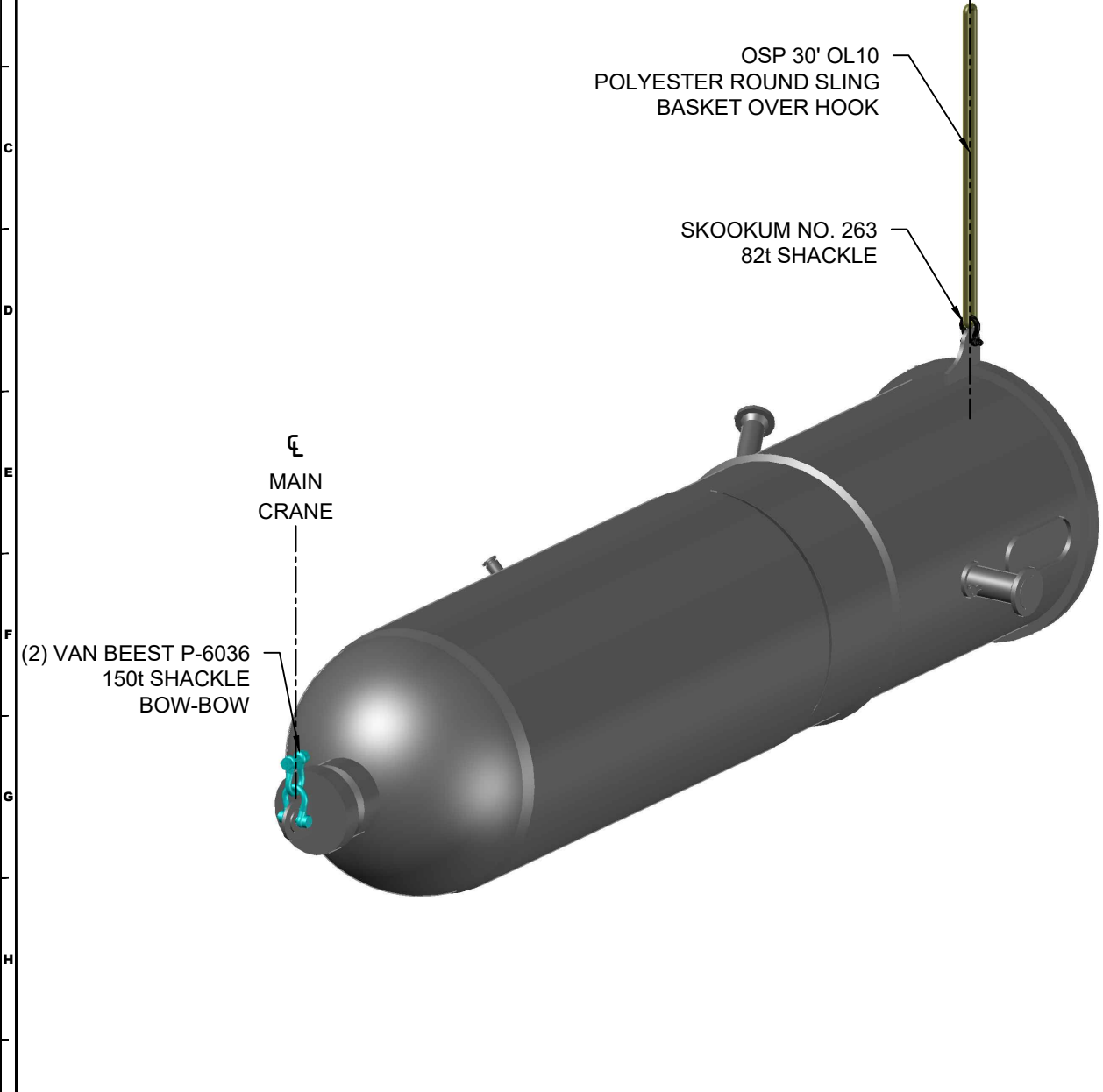

ISOMETRIC VIEW

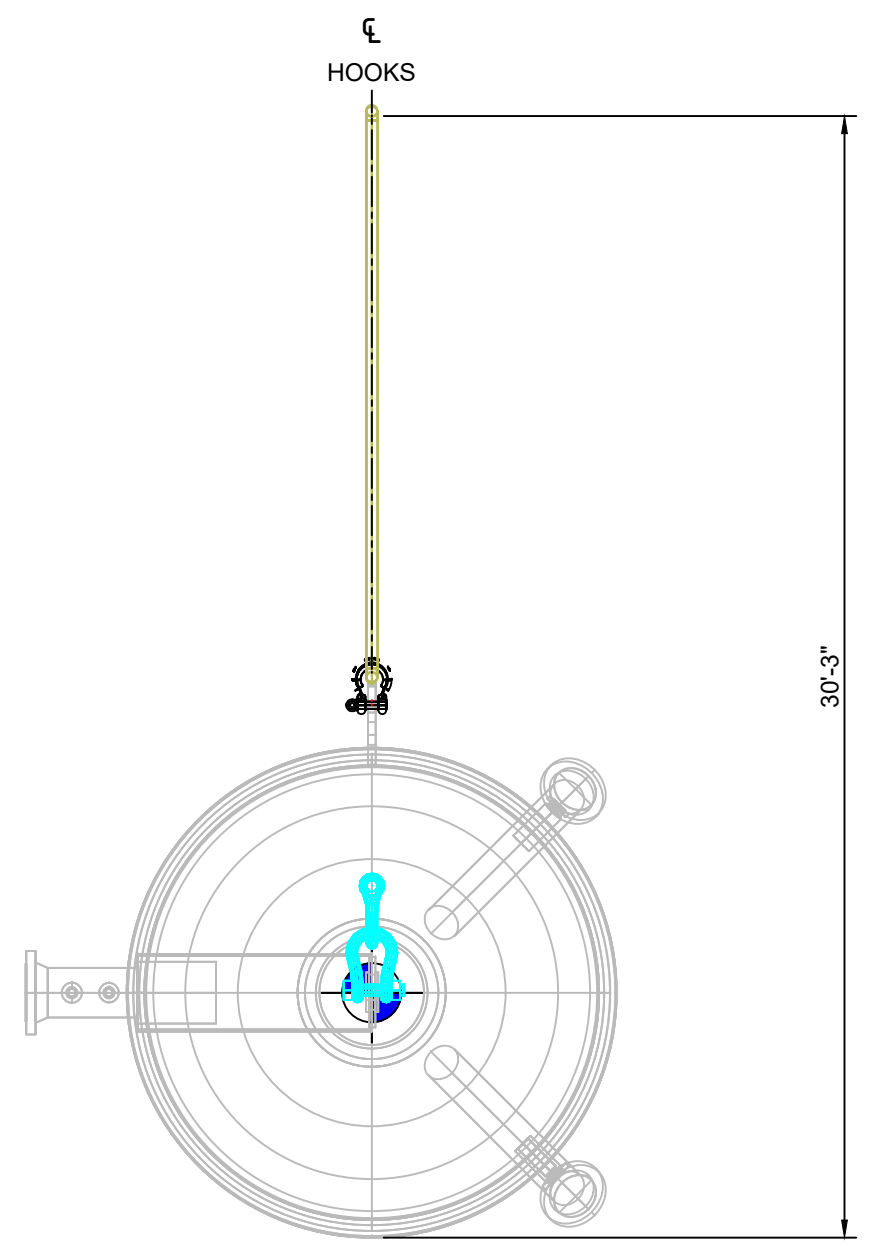

FRONT VIEW

GENERAL NOTES:  
 1. MINIMUM RIGGING COMPONENTS DETAILED. ALTERNATIVE RIGGING COMPONENTS MAY BE USED GIVEN THEY MEET OR EXCEED THE COMPONENTS DETAILED.

REV #	REVISIONS	DATE	REV BY	CHK BY



OFFICES:  
 SEATTLE DIVISION - 1821 180TH ST S.E. BOTHELL, WA 98031 (206) 784-1054  
 PORTLAND DIVISION - 5730 NE 138TH AVE PORTLAND, OR 97320 (503) 283-3111

DISCLOSURE:  
 THIS DOCUMENT IS THE PROPERTY OF NESS & CAMPBELL CRANE, INC. THIS DOCUMENT SHALL NOT BE REPRODUCED, COPIED, DISCLOSED TO OTHERS, OR USED FOR ANY PURPOSE OTHER THAN THAT FOR WHICH IT WAS FURNISHED WITHOUT PRIOR WRITTEN CONSENT OF NESS & CAMPBELL CRANE, INC.

TITLE:	V-6689 NHT REACTOR ERECTION
PROJECT:	CPUP, ANACORTES, WA.
CUSTOMER:	TESORO REFINING AND MARKETING CO.
DESCRIPTION:	RIGGING DETAILS

DATE:	11/1/2016
DRAWN BY:	M.A.
APPROVED BY:	M.A.
SCALE:	AS SHOWN
SHEET:	2 OF 2