

# BOOM TRUCK 55 TONS

NATIONAL NBT50/55

BOOM LENGTHS:  
32 TO 128 FT

JIB LENGTHS:  
26 TO 45 FT

JIB OFFSETS:  
0 - 30



# NOTES:

# National Crane Series NBT50

## Product Guide

ASME B30.5  
Imperial 85%

### Features

- 31,1 m (102 ft) four-section full power boom or optional **39,01 m (128 ft) five-section full power boom**
- 45,36 t (50 USt) at 2,44 m (8 ft) rating and 49,90 t (55 USt) at 2,44 m (8 ft)
- Self-lubricating Easy Glide wear pads
- Hydraulic removable counterweight system
- Outrigger design eliminates need for SFO





# Features

## National Crane NBT50

- 45,36 t (50 USt) maximum capacity
- 41,1 m (135 ft) maximum tip height (main boom)
- 54,6 m (179 ft) maximum tip height (boom with extension)

## National Crane NBT55

- 49,90 t (55 USt) maximum capacity
- 41,1 m (135 ft) maximum tip height (main boom)
- 54,6 m (179 ft) maximum tip height (boom with extension)



## Deluxe operator's cab

The Series NBT50 operator's cab includes all-steel construction with acoustical lining and tinted glass throughout, air conditioning, deluxe seat with arm rest mounted single-axis electric controllers, windshield and sliding skylight with electric wipers, diesel heater with defroster, circulating fan, fire extinguisher, and dual cab mounted work lights.



## Counterweight

Two-piece 1360,8 kg (3000 lb) each (total 2721,6 kg [6000 lb]) hydraulically removable counterweight slabs. Removable counterweight slabs can be stowed on front outrigger box for roading.



## Outriggers

Equipped with left, right ground level and in-cab outrigger controls. The Series NBT50 outriggers allow quick and easy crane set-up and includes a new outrigger beam position sensing system that aids the operator in selecting the right load chart based on the crane's outrigger footprint. The front outrigger box has an X-shaped footprint that eliminates the need for a single front outrigger.

## Dimensions:

Full span:

Front: 7,09 m (23 ft 3 in) Rear: 7,39 m (24 ft 3 in)

Mid span:

Front: 4,72 m (15 ft 6 in) Rear: 4,90 m (16 ft 1 in)

Retracted-front and rear: 2,39 m (7 ft 10 in)



## Four or five-section boom

The Series NBT50 can be equipped with two different boom lengths 31,1 m (102 ft) and 39,01 m (128 ft).



PORTLAND OFFICE: 503.283.3111  
SEATTLE OFFICE: 206.784.1054

[WWW.NESSCAMPBELL.COM](http://WWW.NESSCAMPBELL.COM)

## Best in class performance and serviceability

The Series NBT50 represents the pinnacle of machine performance, combining the latest in both hydraulic and electronic machine control. This product provides premium operator comfort with the latest Manitowoc cab design, simplified machine setup with no need for an SFO and front bumper control of the hoist(s).

- The cable follower will keep constant tension on the rope reducing the potential for bundling
- Speedy-reeve boom tip and sheave blocks simplify rigging changes by decreasing the time needed to change line reeving
- Easy Glide boom wear pads reduce the conditions that cause boom chatter and vibration. The net result is smoother crane operation
- Pressure compensated, load sensing hydraulic system
  - PTO mounted axial piston pump
  - Superstructure mounted reservoir with integral suction valve/filter, return filter, sight gauge, and temperature gauge
  - Oil cooler with 406 mm (16 in) fan and temperature sensor
  - Pressure transducers integral to the lift cylinder holding valve
- LMI system features a 178 mm (7 in) graphical, color display. Real-time crane information is displayed with numerous operator features such as soft metric load chart conversion, hydraulic filter change reminders and an electronic hour meter. LMI system also displays key truck diagnostics such as fuel level, coolant temperature and DPF status
- The display console allows each crane control function to be set independently to reduce speed (100%, 75%, 50%, and 30%)
- Dual axis controls are optional for superior operator control, along with standard air conditioning, a diesel heater and ergonomic seats



*\*Product may be shown with optional equipment.*



PORTLAND OFFICE: 503.283.3111  
SEATTLE OFFICE: 206.784.1054  
[WWW.NESSCAMPBELL.COM](http://WWW.NESSCAMPBELL.COM)

# Specifications

## Boom and extension combinations data

**NBT50 Series Available in two basic models:**

**NBT50-102:** Equipped with a 9,51 m - 31,1 m (31.2 ft - 102 ft) four-section boom. This model can be equipped with an optional 7,9 m - 13,7 m (26 ft - 45 ft) extension, providing a maximum tip height of 46,9 m (154 ft).



9,51 m - 31,1 m (31.2 ft - 102 ft) four-section boom

**FJM-OS** 7,9 m - 13,7 m (26 ft - 45 ft) two-section offsettable at 0° and 30° manual extension



**NBT50-128:** Equipped with a 9,7 m - 39,0 m (31.7 ft - 128 ft) five-section boom. This model can be equipped with an optional 7,9 m - 13,7 m (26 ft - 45 ft) two-section offsettable extension, providing a maximum tip height of 54,6 m (179 ft)



9,7 m - 39,0 m (31.7 ft - 128 ft) five-section full power boom

**FJM-OS** 7,9 m - 13,7 m (26 ft - 45 ft) two-section offsettable 0° and 30° manual extension



**NBT55 - 102:** Equipped with a 9,51 m - 31,1 m (31.2 ft - 102 ft) four-section boom. This model can be equipped with an optional 7,9 m - 13,7 m (26 ft - 45 ft) extension, providing a maximum tip height of 46,9 m (154 ft).



9,51 m - 31,1 m (31.2 ft - 102 ft) four-section boom

**FJM-OS** 7,9 m - 13,7 m (26 ft - 45 ft) two-section offsettable at 0° and 30° manual extension



**NBT55-128:** Equipped with a 9,7 m - 39,0 m (31.7 ft - 128 ft) five-section boom. This model can be equipped with an optional 7,9 m - 13,7 m (26 ft - 45 ft) two-section offsettable extension, providing a maximum tip height of 54,6 m (179 ft)



9,7 m - 39,0 m (31.7 ft - 128 ft) five-section full power boom

**FJM-OS** 7,9 m - 13,7 m (26 ft - 45 ft) two-section offsettable 0° and 30° manual extension



**Note:** Maximum tip is measured with outriggers/stabilizers fully extended.

# Specifications

## NBT50 and NBT55 winch data

- All winch pulls and speeds are shown on the fourth layer.
- Winch line pulls would increase on the first, second, and third layers.
- Winch line speed would decrease on the first, second, and third layers.
- Winch line pulls may be limited by the winch capacity or the ANSI 5 to 1 cable safety factor.

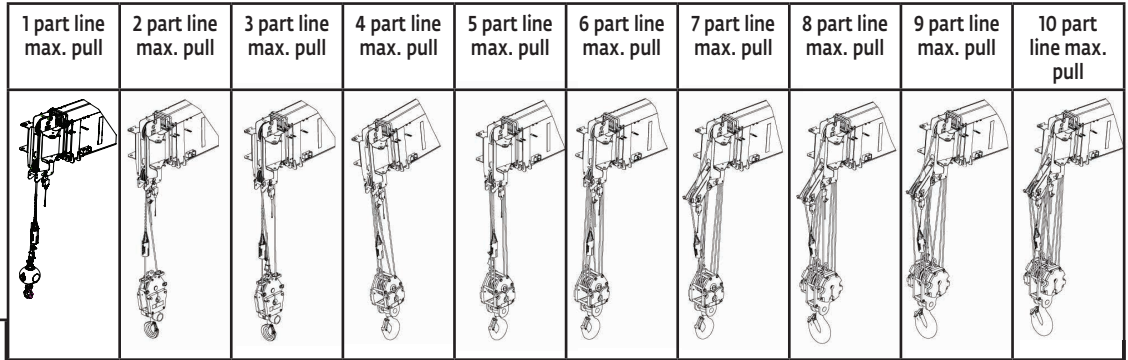

Standard planetary winch	Cable supplied	Average breaking strength	1 sheave		3 sheave				5 sheave			
			1 part line max. pull	2 part line max. pull	3 part line max. pull	4 part line max. pull	5 part line max. pull	6 part line max. pull	7 part line max. pull	8 part line max. pull	9 part line max. pull	10 part line max. pull
Low speed	16 mm (5/8 in) diameter rotation resistant IWRC	25 583 kg (56,400 lb)	5103 kg (11,250 lb) 58,2 m/min (191 fpm)	10 206 kg (22,500 lb) 28,9 m/min (95 fpm)	15 309 kg (33,750 lb) 14,2 m/min (63 fpm)	20 412 kg (45,000 lb) 17,3 m/min (47 fpm)	25 515 kg (56,250 lb) 11,6 m/min (38 fpm)	30 618 kg (67,500 lb) 9,4 m/min (31 fpm)	35 721 kg (78,750 lb) 8,2 m/min (27 fpm)	40 824 kg (90,000 lb) 7,0 m/min (23 fpm)	45 359 kg (100,000 lb) 6,4 m/min (21 fpm)	48 895 kg (110,000 lb) 5,8 m/min (19 fpm)
High speed	16 mm (5/8 in) diameter rotation resistant IWRC	25 583 kg (56,400 lb)	2268 kg (5000 lb) 116,7 m/min (383 fpm)	4536 kg (10,000 lb) 58,2 m/min (191 fpm)	6804 kg (15,000 lb) 38,7 m/min (127 fpm)	9072 kg (20,000 lb) 28,9 m/min (95 fpm)	11 340 kg (25,000 lb) 23,2 m/min (76 fpm)	13 608 kg (30,000 lb) 19,2 m/min (63 fpm)	15 876 kg (35,000 lb) 16,5 m/min (54 fpm)	18 144 kg (40,000 lb) 14,3 m/min (47 fpm)	20 412 kg (45,000 lb) 12,8 m/min (42 fpm)	22 680 kg (50,000 lb) 11,6 m/min (38 fpm)

Winch	Fourth layer pull	Allowable cable pull
Standard planetary and auxiliary planetary	2268 kg (5000 lb) high speed 5117 kg (11,280 lb) low speed	5117 kg (11,280 lb) 5117 kg (11,280 lb)

Loadline deduct		
	Aux boom nose	36 kg (80 lb)
7 USt	Downhaul weight	78 kg (171 lb)
20 USt	1-sheave block	181 kg (400 lb)
40 USt	3-sheave block	272 kg (500 lb)
55 USt	5-sheave block	498 kg (1098 lb)



PORTLAND OFFICE: 503.283.3111  
SEATTLE OFFICE: 206.784.1054  
[WWW.NESSCAMPBELL.COM](http://WWW.NESSCAMPBELL.COM)

Weight and Center of Gravity (CG) estimates (see notes)				
Standard NBT Configuration	Horizontal CG mm (in)	Weight with fluids kg (lb)	CWT Pinned (# slabs)	CWT Stowed (# slabs)
NBT55102	348 (13.7)	20 789 (45,832)	2	0
NBT55102	803 (31.6)	20 789 (45,832)	1	1
NBT55102	1267 (49.9)	20 789 (45,832)	0	2
NBT50102	616 (24.3)	19 421 (42,816)	1	0
NBT50102	1113 (43.8)	19 421 (42,816)	0	1
NBT50102	1011 (39.8)	17,710 (39,044)	0	0
NBT55128	486 (19.1)	21 837 (48,142)	2	0
NBT55128	919 (36.2)	21 837 (48,142)	1	1
NBT55128	1361 (53.6)	21 837 (48,142)	0	2
NBT50128	749 (29.5)	20 469 (45,126)	1	0
NBT50128	1221 (48.0)	20 469 (45,126)	0	1
NBT50128	1134 (44.6)	18 758 (41,354)	0	0

### Weight and CG Estimate Notes:

- Information provided is for reference only.
- Weight and CG data is applicable for a standard machine:
  - 102 ft or 128 ft boom
  - 2/3 part lineblock included
  - Main hoist only (auxiliary hoist IPO CWT present)
  - STD decking with fixed access ladder
  - No extension equipped
  - No optional turret access step
  - No auxiliary nose or optional hook blocks.
- All counterweight configurations are shown in table
  - Pinned = attached to cylinders and turret (in use)
  - Stowed = attached to torsion box (not in use)
  - “2” = Top and bottom slab(s)
  - “1” = Top or bottom slab only
  - “0” = No slab pinned and/or stowed

If both stowed and pinned columns are “0” the counterweight is physically removed from the machine. IPO counterweight is also assumed removed in this case (if no auxiliary hoist is equipped).

For more information about mounting configuration options, please contact the factory or your local National Crane dealer.



PORTLAND OFFICE: 503.283.3111  
 SEATTLE OFFICE: 206.784.1054  
[WWW.NESSCAMPBELL.COM](http://WWW.NESSCAMPBELL.COM)



# Dimensions

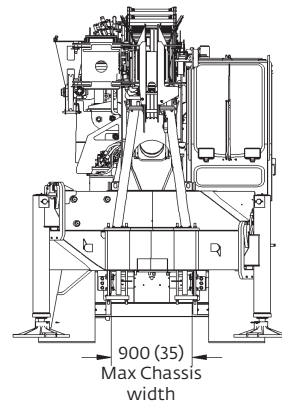
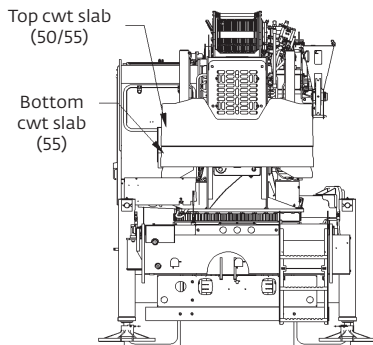
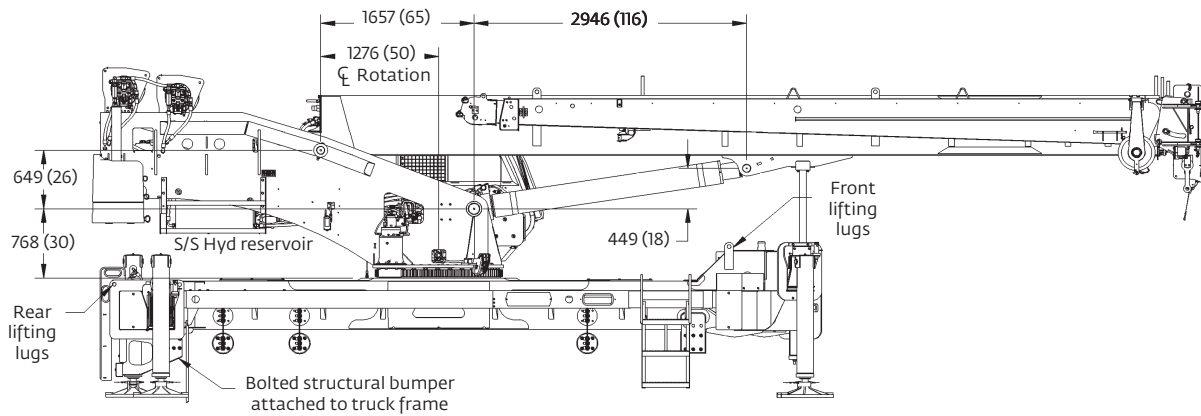
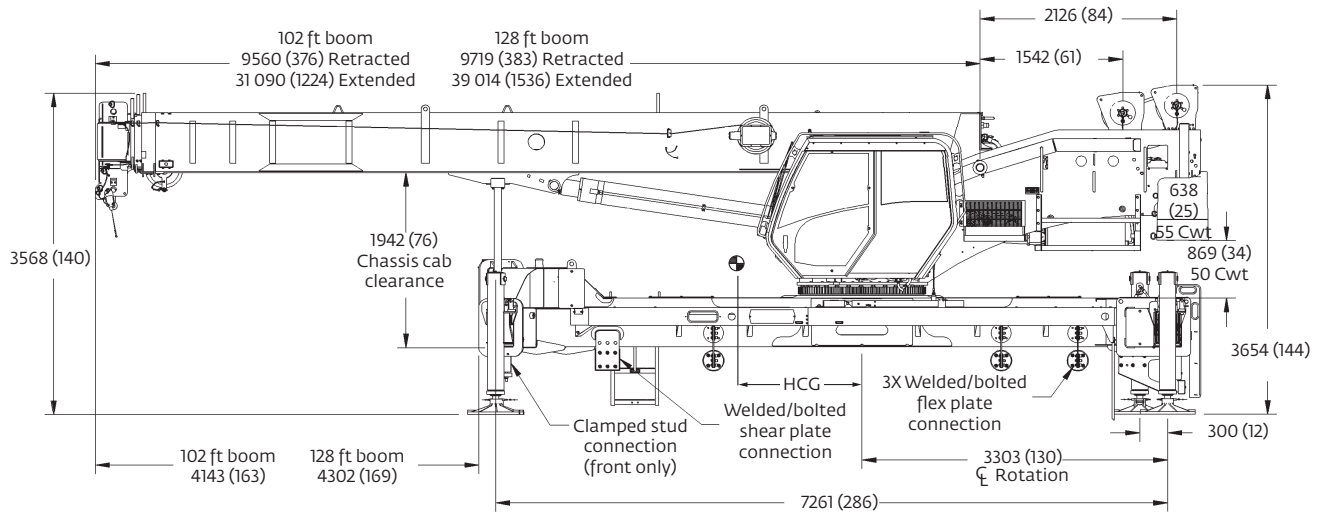

PORTLAND OFFICE: 503.283.3111  
SEATTLE OFFICE: 206.784.1054  
[WWW.NESSCAMPBELL.COM](http://WWW.NESSCAMPBELL.COM)

# Working range

**NBT50/55-128 128 ft main boom, with extensions**

(Boom deflection not shown)

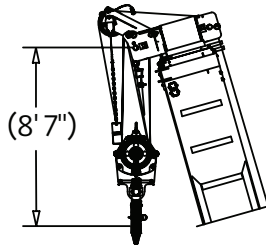
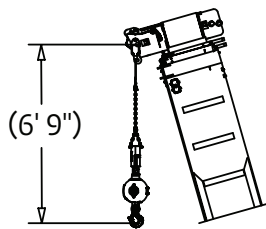
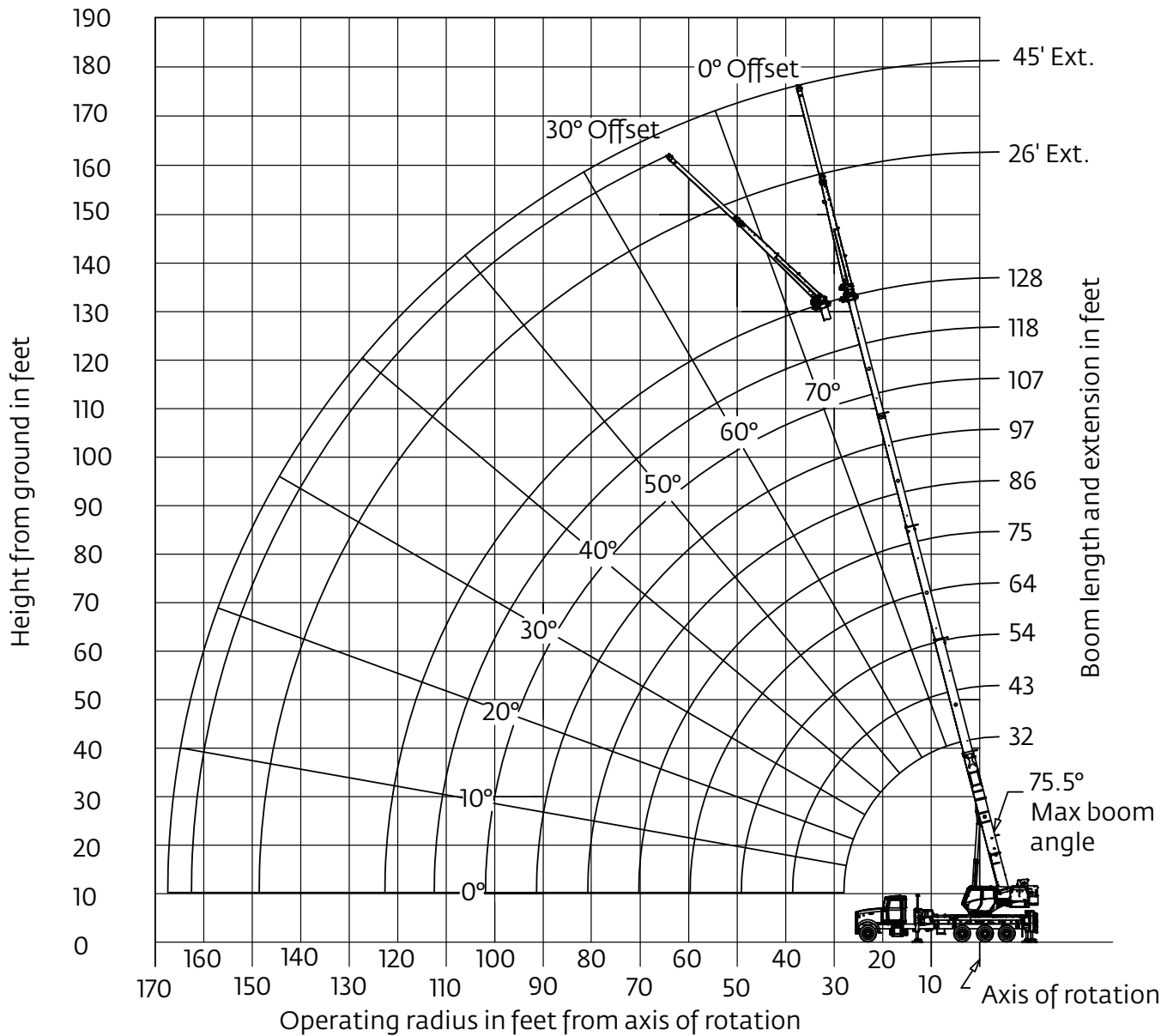

Dimensions are for largest furnished hook block and headache ball with anti-two block activated.



PORTLAND OFFICE: 503.283.3111  
SEATTLE OFFICE: 206.784.1054  
[WWW.NESSCAMPBELL.COM](http://WWW.NESSCAMPBELL.COM)

# Load chart

**NBT55**



39,0 m  
(128 ft)



2722 kg  
(6000 lb)



Outriggers



360°

Radius in feet	#0001									
	Main boom length in feet									
	31.7	43-A	54-B	64-C	75-D	86-E	97-F	107-G	118-H	128
8	110,000 (68.1)									
10	92,300 (64.0)	40,050 (71.3)								
12	81,200 (59.8)	40,050 (68.5)	40,350 (73.3)							
15	65,400 (53.1)	40,050 (64.0)	40,350 (69.9)	40,300 (73.5)						
20	47,750 (40.3)	40,050 (56.2)	40,350 (64.2)	40,300 (68.8)	34,100 (72.5)					
25	31,650 (21.8)	37,700 (47.5)	38,150 (58.0)	37,150 (63.9)	30,100 (68.4)	22,650 (71.5)				
30		30,200 (37.3)	30,700 (51.3)	31,000 (58.6)	27,100 (64.2)	20,400 (68.0)	17,800 (71.2)			
35		22,300 (23.6)	25,100 (43.9)	25,350 (53.1)	24,600 (59.8)	18,500 (64.3)	16,300 (68.0)	14,700 (70.8)	12,900 (73.2)	
40			20,700 (35.2)	21,050 (47.0)	21,350 (55.1)	17,050 (60.5)	15,100 (64.7)	13,650 (68.0)	12,050 (70.8)	10,850 (73.0)
45			*16,400 (24.0)	16,950 (40.3)	17,200 (50.0)	15,800 (56.5)	14,000 (61.5)	12,550 (65.0)	11,300 (68.2)	10,250 (70.8)
50				13,900 (32.4)	14,150 (44.6)	14,400 (52.3)	12,850 (58.0)	11,750 (62.0)	10,650 (65.8)	9650 (68.4)
55				11,600 (22.2)	11,850 (38.6)	12,050 (47.8)	12,000 (54.4)	10,950 (59.2)	10,000 (63.2)	8750 (65.9)
60					10,100 (32.4)	10,300 (43.3)	10,450 (50.8)	10,300 (56.0)	9400 (60.4)	7850 (63.3)
65					8550 (23.9)	8750 (37.9)	8950 (46.6)	9100 (52.4)	8850 (57.5)	7000 (60.6)
70					*4650 (9.2)	7500 (31.8)	7650 (42.1)	7800 (48.7)	7950 (54.3)	6300 (57.9)
75						6450 (24.3)	6600 (37.2)	6750 (44.7)	6850 (51.0)	5700 (55.0)
80						*4400 (12.8)	5700 (31.6)	5800 (40.5)	5950 (47.5)	5150 (52.1)
85							4900 (24.8)	5000 (35.8)	5150 (43.8)	4650 (49.0)
90							*3850 (15.3)	4300 (30.4)	4450 (39.8)	4150 (45.7)
95								3700 (24.0)	3800 (35.4)	3700 (42.2)
100								*2800 (14.9)	3300 (30.5)	3300 (38.4)
105									2800 (24.6)	2850 (34.2)
110									2350 (16.8)	2450 (29.5)
115										*1900 (23.7)
120										*1100 (15.8)
Minimum boom angle (°) for indicated length (no load)							0	5	8	10
Maximum boom length (ft) at 0° boom angle (no load)							97			

NOTE: ( ) Boom angles are in degrees.  
 \*Loads are structurally limited.  
 #LMI operating code. Refer to LMI manual for operating instructions.

Lifting capacities at zero degree boom angle										
Boom angle	Main boom length in feet									
	31.7	43-A	54-B	64-C	75-D	86-E				
0°	12,900 (27.5)	7600 (38.8)	4850 (19.8)	3700 (59.8)	2200 (70.8)	1150 (81.8)				

NOTE: ( ) Reference radii in feet. 80034324



PORTLAND OFFICE: 503.283.3111  
 SEATTLE OFFICE: 206.784.1054  
[WWW.NESSCAMPBELL.COM](http://WWW.NESSCAMPBELL.COM)

# Load chart

**NBT55**



39,0 m  
(128 ft)



Jib Stowed



2722 kg  
(6000 lb)

Counterweight



100%

Outriggers



360°

Radius in feet	#0002									
	Main boom length in feet									
	31.7	43-A	54-B	64-C	75-D	86-E	97-F	107-G	118-H	128
8	108,850 (68.1)									
10	91,150 (64.0)	39,250 (71.3)								
12	80,050 (59.8)	39,250 (68.5)	39,250 (73.3)							
15	64,250 (53.1)	39,250 (64.0)	39,250 (69.9)	39,250 (73.5)						
20	46,600 (40.3)	39,250 (56.2)	39,250 (64.2)	39,250 (68.8)	33,650 (72.5)					
25	30,500 (21.8)	36,900 (47.5)	37,550 (58.0)	36,650 (63.9)	29,650 (68.4)	22,250 (71.5)				
30		29,400 (37.3)	30,100 (51.3)	30,500 (58.6)	26,650 (64.2)	20,000 (68.0)	17,450 (71.2)			
35		21,500 (23.6)	24,500 (43.9)	24,850 (53.1)	24,150 (59.8)	18,100 (64.3)	15,950 (68.0)	14,400 (70.8)	12,600 (73.2)	
40			20,100 (35.2)	20,550 (47.0)	20,900 (55.1)	16,650 (60.5)	14,750 (64.7)	13,350 (68.0)	11,750 (70.8)	10,600 (73.0)
45			15,800 (24.0)	16,450 (40.3)	16,750 (50.0)	15,400 (56.5)	13,650 (61.5)	12,250 (65.0)	11,000 (68.2)	10,000 (70.8)
50				13,400 (32.4)	13,700 (44.6)	14,000 (52.3)	12,500 (58.0)	11,450 (62.0)	10,350 (65.8)	9400 (68.4)
55				11,100 (22.2)	11,400 (38.6)	11,650 (47.8)	11,650 (54.4)	10,650 (59.2)	9700 (63.2)	8500 (65.9)
60					9650 (32.4)	9900 (43.3)	10,100 (50.8)	10,000 (56.0)	9100 (60.4)	7600 (63.3)
65					8100 (23.9)	8350 (37.9)	8600 (46.6)	8800 (52.4)	8550 (57.5)	6750 (60.6)
70					*4200 (9.2)	7100 (31.8)	7300 (42.1)	7500 (48.7)	7650 (54.3)	6050 (57.9)
75						6050 (24.3)	6250 (37.2)	6450 (44.7)	6550 (51.0)	5450 (55.0)
80						*4000 (12.8)	5350 (31.6)	5500 (40.5)	5650 (47.5)	4900 (52.1)
85							4550 (24.8)	4700 (35.8)	4850 (43.8)	4400 (49.0)
90							*3500 (15.3)	4000 (30.4)	4150 (39.8)	3900 (45.7)
95								3400 (24.0)	3500 (35.4)	3450 (42.2)
100								*2500 (14.9)	3000 (30.5)	3050 (38.4)
105									2500 (24.6)	2600 (34.2)
110									2050 (16.8)	2200 (29.5)
115										*1650 (23.7)
120										*850 (15.8)
Minimum boom angle (°) for indicated length (no load)							0	5	8	10
Maximum boom length (ft.) at 0° boom angle (no load)							97			

NOTE: ( ) Boom angles are in degrees.

\*Loads are structurally limited.

#LMI operating code. Refer to LMI manual for operating instructions.

Boom angle	Lifting capacities at zero degree boom angle									
	Main boom length in feet									
	31.7	43-A	54-B	64-C	75-D	86-E				
0°	11,750 (27.5)	6,800 (38.8)	4,250 (19.8)	3,200 (59.8)	1,750 (70.8)	750 (81.8)				

NOTE: ( ) Reference radii in feet.

80034325



PORTLAND OFFICE: 503.283.3111  
SEATTLE OFFICE: 206.784.1054

WWW.NESSCAMPBELL.COM

# Load chart

## NBT55



39,0 m  
(128 ft)



2722 kg  
(6000 lb)



Outriggers



Over Rear

Radius in feet	#0003									
	Main boom length in feet									
	31.7	43-A	54-B	64-C	75-D	86-E	97-F	107-G	118-H	128
8	110,000 (68.1)									
10	92,300 (64.0)	40,050 (71.3)								
12	81,200 (59.8)	40,050 (68.5)	40,350 (73.3)							
15	65,400 (53.1)	40,050 (64.0)	40,350 (69.9)	40,300 (73.5)						
20	47,750 (40.3)	40,050 (56.2)	40,350 (64.2)	40,300 (68.8)	34,100 (72.5)					
25	31,650 (21.8)	37,700 (47.5)	38,150 (58.0)	37,150 (63.6)	30,100 (68.4)	22,650 (71.5)				
30		30,200 (37.3)	30,700 (51.3)	31,000 (58.3)	27,100 (64.2)	20,400 (67.8)	17,800 (71.2)			
35		22,300 (23.6)	25,100 (43.9)	25,350 (52.7)	24,600 (59.8)	18,500 (64.0)	16,300 (68.0)	14,700 (70.8)	12,900 (73.2)	
40			20,950 (35.2)	21,250 (47.3)	21,500 (55.1)	17,050 (60.4)	15,100 (64.8)	13,650 (68.0)	12,050 (70.8)	10,850 (73.0)
45			16,400 (24.0)	18,000 (40.7)	18,250 (50.1)	15,800 (56.4)	14,000 (61.5)	12,550 (65.0)	11,300 (68.2)	10,250 (70.8)
50				15,250 (33.0)	15,500 (44.7)	14,600 (52.1)	12,850 (58.0)	11,750 (62.0)	10,650 (65.8)	9650 (68.4)
55				*11,900 (23.2)	13,100 (38.7)	13,300 (47.6)	12,000 (54.4)	10,950 (59.2)	10,000 (63.2)	8750 (65.9)
60					11,200 (32.5)	11,400 (42.8)	11,250 (50.5)	10,300 (56.0)	9400 (60.4)	7850 (63.3)
65					9700 (23.9)	9900 (37.4)	10,100 (46.8)	9700 (52.6)	8850 (57.5)	7000 (60.6)
70					*4650 (9.2)	8600 (31.3)	8750 (42.3)	8900 (48.9)	8400 (54.5)	6300 (57.9)
75						7450 (23.8)	7600 (37.3)	7750 (45.0)	7900 (51.3)	5700 (55.0)
80						*4400 (12.6)	6650 (31.7)	6800 (40.7)	6900 (47.8)	5150 (52.1)
85							5800 (25.0)	5950 (36.0)	6050 (44.1)	4650 (49.0)
90							*3850 (15.3)	5200 (30.7)	5300 (40.1)	4150 (45.7)
95								4550 (24.2)	4650 (35.7)	3700 (42.2)
100								*2800 (14.9)	4050 (30.8)	3300 (38.4)
105									3550 (24.9)	3000 (34.3)
110									*2400 (16.8)	2650 (29.6)
115										1900 (23.7)
120										1100 (15.8)
Minimum boom angle (°) for indicated length (no load)							0	5	8	10
Maximum boom length (ft.) at 0° boom angle (no load)							97			

NOTE: ( ) Boom angles are in degrees.

\*Loads are structurally limited.

#LMI operating code. Refer to LMI manual for operating instructions.

Boom angle	Lifting capacities at zero degree boom angle									
	Main boom length in feet									
	31.7	43-A	54-B	64-C	75-D	86-E				
0°	12,900 (27.5)	7600 (38.8)	4850 (19.8)	3700 (59.8)	2200 (70.8)	1150 (81.8)				

NOTE: ( ) Reference radii in feet.

80034328



PORTLAND OFFICE: 503.283.3111  
SEATTLE OFFICE: 206.784.1054

WWW.NESSCAMPBELL.COM



# Load chart

**NBT55**



39,0 m  
(128 ft)



Jib Stowed



2722 kg  
(6000 lb)

Counterweight



100%

Outriggers



Over Rear

Radius in feet	#0004									
	Main boom length in feet									
	31.7	43-A	54-B	64-C	75-D	86-E	97-F	107-G	118-H	128
8	108,850 (68.1)									
10	91,150 (64.0)	39,250 (71.3)								
12	80,050 (59.8)	39,250 (68.5)	39,250 (73.3)							
15	64,250 (53.1)	39,250 (64.0)	39,250 (69.9)	39,250 (73.5)						
20	46,600 (40.3)	39,250 (56.2)	39,250 (64.2)	39,250 (68.8)	33,650 (72.5)					
25	30,500 (21.8)	36,900 (47.5)	37,550 (58.0)	36,650 (63.9)	29,650 (68.4)	22,250 (71.5)				
30		29,400 (37.3)	30,100 (51.3)	30,500 (58.6)	26,650 (64.2)	20,000 (68.0)	17,450 (71.2)			
35		21,500 (23.6)	24,500 (43.9)	24,850 (53.1)	24,150 (59.8)	18,100 (64.3)	15,950 (68.0)	14,400 (70.8)	12,600 (73.2)	
40			20,350 (35.2)	20,750 (47.0)	21,050 (55.1)	16,650 (60.5)	14,750 (64.8)	13,350 (68.0)	11,750 (70.8)	10,600 (73.0)
45			15,800 (24.0)	17,500 (40.3)	17,800 (50.1)	15,400 (56.5)	13,650 (61.5)	12,250 (65.0)	11,000 (68.2)	10,000 (70.8)
50				14,750 (32.4)	15,050 (44.7)	14,200 (52.1)	12,500 (58.0)	11,450 (62.0)	10,350 (65.8)	9400 (68.4)
55				*11,400 (22.2)	12,650 (38.7)	12,900 (47.6)	11,650 (54.4)	10,650 (59.2)	9700 (63.2)	8500 (65.9)
60					10,750 (32.5)	11,000 (42.8)	10,900 (50.5)	10,000 (56.0)	9100 (60.4)	7600 (63.3)
65					9250 (23.9)	9500 (37.4)	9750 (46.8)	9400 (52.6)	8550 (57.5)	6750 (60.6)
70					*4200 (9.2)	8200 (31.3)	8400 (42.3)	8600 (48.9)	8100 (54.5)	6050 (57.9)
75						7050 (23.8)	7250 (37.3)	7450 (45.0)	7600 (51.3)	5450 (55.0)
80						*4000 (12.6)	6300 (31.7)	6500 (40.7)	6600 (47.8)	4900 (52.1)
85							5450 (25.0)	5650 (36.0)	5750 (44.1)	4400 (49.0)
90							*3500 (15.3)	4900 (30.7)	5000 (40.1)	3900 (45.7)
95								4250 (24.2)	4350 (35.7)	3450 (42.2)
100								*2500 (14.9)	3750 (30.8)	3050 (38.4)
105									3250 (24.9)	2750 (34.3)
110									*2100 (16.8)	2400 (29.6)
115										1650 (23.7)
120										850 (15.8)
Minimum boom angle (°) for indicated length (no load)							0	5	8	10
Maximum boom length (ft) at 0° boom angle (no load)							97			

NOTE: ( ) Boom angles are in degrees.

\*Loads are structurally limited.

#LMI operating code. Refer to LMI manual for operating instructions.

Lifting capacities at zero degree boom angle									
Boom angle	Main boom length in feet								
	31.7	43-A	54-B	64-C	75-D	86-E			
0°	11,750 (27.5)	6800 (38.8)	4250 (19.8)	3200 (59.8)	1750 (70.8)	750 (81.8)			

NOTE: ( ) Reference radii in feet.

80034329



PORTLAND OFFICE: 503.283.3111  
SEATTLE OFFICE: 206.784.1054

WWW.NESSCAMPBELL.COM

# Load chart

**NBT55**



7,9 m - 13,7 m  
(26 ft - 45 ft)



2722 kg  
(6000 lb)



Outriggers



100%

360°

Radius in feet	26 ft LENGTH		45 ft LENGTH	
	#0005	#0007	#0009	#0011
	0° OFFSET	30° OFFSET	0° OFFSET	30° OFFSET
50	6000 (72.6)			
55	5800 (70.8)			
60	5500 (69.0)			
65	5200 (67.0)	4900 (72.1)	4050 (70.4)	
70	4850 (65.0)	4650 (69.9)	4000 (68.8)	
75	4500 (62.9)	4400 (67.7)	3950 (67.2)	2800 (73.8)
80	4250 (60.8)	4150 (65.4)	3900 (65.6)	2700 (71.9)
85	3950 (58.6)	4000 (63.1)	3800 (63.9)	2650 (70.0)
90	3800 (56.4)	3800 (60.7)	3550 (62.0)	2600 (68.0)
95	3650 (54.1)	3650 (58.3)	3250 (59.9)	2550 (66.0)
100	3150 (51.5)	3350 (55.6)	3000 (57.8)	2500 (63.9)
105	2600 (48.6)	2900 (52.6)	2700 (55.6)	2450 (61.8)
110	2100 (45.7)	2550 (49.6)	2500 (53.5)	2400 (59.5)
115	1700 (42.6)	2100 (46.3)	2300 (51.2)	2350 (57.2)
120	1350 (39.4)	*1650 (42.8)	2050 (48.7)	2300 (54.7)
125	950 (35.9)	*1200 (39.0)	1750 (46.1)	2250 (52.1)
130	650 (32.1)	*850 (34.8)	1500 (43.4)	2000 (49.1)
135		*450 (30.0)	1200 (40.4)	1600 (45.7)
140			900 (37.3)	1250 (42.2)
145			650 (33.9)	*900 (38.3)
150				*600 (33.9)
Min. boom angle for indicated length (no load)	29°	30°	30°	31°
Max. boom length at 0° boom angle (no load)	64 ft		64 ft	

NOTE: ( ) Boom angles are in degrees.

80034336

#LMI operating code. Refer to LMI manual for instructions.

\*Loads are structurally limited.

### Boom extension capacity notes:

1. All capacities above the bold line are based on structural strength limitations.
  2. 26 ft and 45 ft extension lengths may be used for single line lifting service.
  3. Radii listed are for a fully extended boom with the boom extension erected. For main boom lengths less than fully extended, the rated loads are determined by boom angle. Use only the column which corresponds to the boom extension length and offset for which the machine is configured. For boom angles not shown, use the rating of the next lower boom angle.
- Warning:** Operation of this machine with heavier loads than the capacities listed is strictly prohibited. Machine tipping with boom extension occurs rapidly and without advance warning.
4. Boom angle is the angle above or below horizontal of the longitudinal axis of the boom base section after lifting rated load.
  5. Capacities listed are with outriggers properly extended and vertical jacks set only.



PORTLAND OFFICE: 503.283.3111  
SEATTLE OFFICE: 206.784.1054

[WWW.NESSCAMPBELL.COM](http://WWW.NESSCAMPBELL.COM)

# Load chart

**NBT55**



7,9 m - 13,7 m  
(26 ft - 45 ft)



2722 kg  
(6000 lb)



Outriggers  
100%



Over Rear

Radius in feet	26 ft LENGTH		45 ft LENGTH	
	#0006	#0008	#0010	#0012
	0° OFFSET	30° OFFSET	0° OFFSET	30° OFFSET
50	6000 (72.6)			
55	5800 (70.8)			
60	5500 (69.0)			
65	5200 (67.0)	4900 (72.1)	4050 (70.4)	
70	4850 (65.0)	4650 (69.9)	4000 (68.8)	
75	4500 (62.9)	4400 (67.7)	3950 (67.2)	2800 (73.8)
80	4250 (60.8)	4150 (65.4)	3900 (65.6)	2700 (71.9)
85	3950 (58.6)	4000 (63.1)	3800 (63.9)	2650 (70.0)
90	3800 (56.4)	3800 (60.7)	3550 (62.0)	2600 (68.0)
95	3650 (54.1)	3650 (58.3)	3250 (59.9)	2550 (66.0)
100	3150 (51.5)	3350 (55.6)	3000 (57.8)	2500 (63.9)
105	2600 (48.6)	2900 (52.6)	2700 (55.6)	2450 (61.8)
110	2100 (45.7)	2550 (49.6)	2500 (53.5)	2400 (59.5)
115	1700 (42.6)	2150 (46.3)	2300 (51.2)	2350 (57.2)
120	1350 (39.4)	1650 (42.8)	2050 (48.7)	2300 (54.7)
125	950 (35.9)	1200 (39.0)	1750 (46.1)	2250 (52.1)
130	650 (32.1)	850 (34.8)	1500 (43.4)	2200 (49.3)
135		450 (30.0)	1200 (40.4)	1750 (45.9)
140			900 (37.3)	1350 (42.3)
145			650 (33.9)	900 (38.3)
150				600 (33.9)
Min. boom angle for indicated length (no load)	29°	30°	30°	31°
Max. boom length at 0° boom angle (no load)	64 ft		64 ft	

NOTE: ( ) Boom angles are in degrees.

80034337

#LMI operating code. Refer to LMI manual for instructions.

## Boom extension capacity notes:

- All capacities above the bold line are based on structural strength limitations.
  - 26 ft and 45 ft extension lengths may be used for single line lifting service.
  - Radii listed are for a fully extended boom with the boom extension erected. For main boom lengths less than fully extended, the rated loads are determined by boom angle. Use only the column which corresponds to the boom extension length and offset for which the machine is configured. For boom angles not shown, use the rating of the next lower boom angle.
- Warning:** Operation of this machine with heavier loads than the capacities listed is strictly prohibited. Machine tipping with boom extension occurs rapidly and without advance warning.
- Boom angle is the angle above or below horizontal of the longitudinal axis of the boom base section after lifting rated load.
  - Capacities listed are with outriggers properly extended and vertical jacks set only.



PORTLAND OFFICE: 503.283.3111  
SEATTLE OFFICE: 206.784.1054

[WWW.NESSCAMPBELL.COM](http://WWW.NESSCAMPBELL.COM)

# Load chart

## NBT50/55



39,0 m  
(128 ft)



1361 kg  
(3000 lb)



Outriggers



360°

Radius in feet	#0001									
	Main boom length in feet									
	31.7	43-A	54-B	64-C	75-D	86-E	97-F	107-G	118-H	128
8	100,000 (68.1)									
10	92,250 (64.0)	40,050 (71.3)								
12	80,100 (59.8)	40,050 (68.5)	40,350 (73.3)							
15	63,450 (53.1)	40,050 (64.0)	40,350 (69.9)	40,300 (73.5)						
20	46,300 (40.2)	40,050 (56.2)	40,350 (64.2)	40,300 (68.8)	34,100 (72.5)					
25	31,650 (21.8)	36,500 (47.5)	36,950 (57.9)	37,150 (63.9)	30,100 (68.4)	22,650 (71.5)				
30		28,950 (37.3)	29,400 (51.2)	29,700 (58.6)	27,100 (64.2)	20,400 (68.0)	17,800 (71.2)			
35		22,300 (23.6)	23,900 (43.8)	24,300 (53.0)	24,550 (59.8)	18,500 (64.3)	16,300 (68.0)	14,700 (70.8)	12,900 (73.2)	
40			18,600 (35.2)	18,950 (47.0)	19,250 (55.0)	17,050 (60.5)	15,100 (64.8)	13,650 (68.0)	12,050 (70.8)	10,850 (73.0)
45			14,800 (24.0)	15,150 (40.2)	15,450 (50.0)	15,650 (56.5)	14,000 (61.5)	12,550 (65.0)	11,300 (68.2)	10,250 (70.8)
50				12,350 (32.4)	12,600 (44.5)	12,800 (52.2)	12,850 (58.0)	11,750 (62.0)	10,650 (65.8)	9650 (68.4)
55				10,300 (23.3)	10,600 (39.2)	10,800 (48.1)	11,000 (54.6)	10,950 (59.2)	10,000 (63.2)	8750 (65.9)
60					8850 (32.3)	9050 (43.2)	9250 (50.6)	9400 (55.8)	9400 (60.4)	7850 (63.3)
65					7450 (23.8)	7650 (37.8)	7800 (46.4)	7950 (52.2)	8100 (57.3)	7000 (60.6)
70					*4650 (9.2)	6500 (31.7)	6650 (41.9)	6800 (48.5)	6900 (54.0)	6300 (57.9)
75						5500 (24.2)	5650 (37.0)	5800 (44.5)	5900 (50.7)	5700 (55.0)
80						*4400 (12.8)	4800 (31.4)	4950 (40.2)	5050 (47.2)	5150 (52.1)
85							4100 (24.7)	4200 (35.6)	4300 (43.5)	4400 (48.9)
90							3450 (15.2)	3550 (30.2)	3650 (39.5)	3750 (45.5)
95								3000 (23.8)	3100 (35.2)	3200 (42.0)
100								2500 (14.8)	2600 (30.2)	2700 (38.1)
105									2150 (24.4)	2250 (33.9)
110									1750 (16.6)	1800 (29.2)
115										1450 (23.5)
120										*1100 (15.8)
Minimum boom angle (°) for indicated length (no load)							0	5	8	10
Maximum boom length (ft) at 0° boom angle (no load)							97			

NOTE: ( ) Boom angles are in degrees.

\*Loads are structurally limited.

#LMI operating code. Refer to LMI manual for operating instructions.

Boom angle	Lifting capacities at zero degree boom angle									
	Main boom length in feet									
	31.7	43-A	54-B	64-C	75-D	86-E				
0°	12,900 (27.5)	7600 (38.8)	4850 (19.8)	3700 (59.8)	2200 (70.8)	1150 (81.8)				

NOTE: ( ) Reference radii in feet.

80034844A



PORTLAND OFFICE: 503.283.3111  
SEATTLE OFFICE: 206.784.1054

WWW.NESSCAMPBELL.COM

# Load chart

**NBT50/55**



39,0 m  
(128 ft)



Jib Stowed



1361 kg  
(3000 lb)

Counterweight



100%

Outriggers



360°

Radius in feet	#0002														
	Main boom length in feet														
	31.7	43-A	54-B	64-C	75-D	86-E	97-F	107-G	118-H	128					
8	98,850 (68.1)														
10	91,100 (64.0)	39,250 (71.3)													
12	78,950 (59.8)	39,250 (68.5)	39,250 (73.3)												
15	62,300 (53.1)	39,250 (64.0)	39,250 (69.9)	39,250 (73.5)											
20	45,150 (40.2)	39,250 (56.2)	39,250 (64.2)	39,250 (68.8)	33,650 (72.5)										
25	30,500 (21.8)	35,700 (47.5)	36,350 (57.9)	36,650 (63.9)	29,650 (68.4)	22,250 (71.5)									
30		28,150 (37.3)	28,800 (51.2)	29,200 (58.6)	26,650 (64.2)	20,000 (68.0)	17,450 (71.2)								
35		21,500 (23.6)	23,300 (43.8)	23,800 (53.0)	24,100 (59.8)	18,100 (64.3)	15,950 (68.0)	14,400 (70.8)	12,600 (73.2)						
40			18,000 (35.2)	18,450 (47.0)	18,800 (55.0)	16,650 (60.5)	14,750 (64.8)	13,350 (68.0)	11,750 (70.8)	10,600 (73.0)					
45			14,200 (24.0)	14,650 (40.2)	15,000 (50.0)	15,250 (56.5)	13,650 (61.5)	12,250 (65.0)	11,000 (68.2)	10,000 (70.8)					
50				11,850 (32.4)	12,150 (44.5)	12,400 (52.2)	12,500 (58.0)	11,450 (62.0)	10,350 (65.8)	9400 (68.4)					
55					9800 (23.3)	10,150 (39.2)	10,400 (48.1)	10,650 (54.6)	10,650 (59.2)	9700 (63.2)	8500 (65.9)				
60						8400 (32.3)	8650 (43.2)	8900 (50.6)	9100 (55.8)	9100 (60.4)	7600 (63.3)				
65						7000 (23.8)	7250 (37.8)	7450 (46.4)	7650 (52.2)	7800 (57.3)	6750 (60.6)				
70						*4200 (9.2)	6100 (31.7)	6300 (41.9)	6500 (48.5)	6600 (54.0)	6050 (57.9)				
75							5100 (24.2)	5300 (37.0)	5500 (44.5)	5600 (50.7)	5450 (55.0)				
80								*4000 (12.8)	4450 (31.4)	4650 (40.2)	4750 (47.2)	4900 (52.1)			
85									3750 (24.7)	3900 (35.6)	4000 (43.5)	4150 (48.9)			
90										3100 (15.2)	3250 (30.2)	3350 (39.5)	3500 (45.5)		
95											2700 (23.8)	2800 (35.2)	2950 (42.0)		
100												2200 (14.8)	2300 (30.2)	2,450 (38.1)	
105													1850 (24.4)	2000 (33.9)	
110														1450 (16.6)	1550 (29.2)
115															1200 (23.5)
120															*850 (15.8)
Minimum boom angle (°) for indicated length (no load)							0	5	8	10					
Maximum boom length (ft) at 0° boom angle (no load)							97								

NOTE: ( ) Boom angles are in degrees.

\*Loads are structurally limited.

#LMI operating code. Refer to LMI manual for operating instructions.

Lifting capacities at zero degree boom angle										
Boom angle	Main boom length in feet									
	31.7	43-A	54-B	64-C	75-D	86-E				
0°	11,750 (27.5)	6800 (38.8)	4250 (19.8)	3200 (59.8)	1750 (70.8)	750 (81.8)				

NOTE: ( ) Reference radii in feet.

80034845A



PORTLAND OFFICE: 503.283.3111  
SEATTLE OFFICE: 206.784.1054

WWW.NESSCAMPBELL.COM



# Load chart

**NBT50/55**



39,0 m  
(128 ft)



1361 kg  
(3000 lb)



Outriggers



Over Rear

Radius in feet	#0003									
	Main boom length in feet									
	31.7	43-A	54-B	64-C	75-D	86-E	97-F	107-G	118-H	128
8	100,000 (68.1)									
10	92,250 (64.0)	40,050 (71.3)								
12	80,100 (59.8)	40,050 (68.5)	40,350 (73.3)							
15	63,450 (53.1)	40,050 (64.0)	40,350 (69.9)	40,300 (73.5)						
20	46,300 (40.2)	40,050 (56.2)	40,350 (64.2)	40,300 (68.8)	34,100 (72.5)					
25	31,650 (21.8)	36,500 (47.5)	36,950 (57.9)	37,150 (63.9)	30,100 (68.4)	22,650 (71.5)				
30		28,950 (37.3)	29,400 (51.2)	29,700 (58.6)	27,100 (64.2)	20,400 (68.0)	17,800 (71.2)			
35		22,300 (23.6)	24,000 (43.8)	24,300 (53.0)	24,550 (59.8)	18,500 (64.3)	16,300 (68.0)	14,700 (70.8)	12,900 (73.2)	
40			20,000 (35.2)	20,300 (47.0)	20,550 (55.1)	17,050 (60.5)	15,100 (64.8)	13,650 (68.0)	12,050 (70.8)	10,850 (73.0)
45			16,400 (24.0)	16,800 (40.3)	17,050 (50.0)	15,800 (56.5)	14,000 (61.5)	12,550 (65.0)	11,300 (68.2)	10,250 (70.8)
50				13,900 (32.4)	14,150 (44.6)	14,350 (52.3)	12,850 (58.0)	11,750 (62.0)	10,650 (65.8)	9650 (68.4)
55				11,650 (22.2)	11,900 (38.6)	12,100 (47.8)	12,000 (54.4)	10,950 (59.2)	10,000 (63.2)	8750 (65.9)
60					10,200 (32.4)	10,400 (43.3)	10,550 (50.8)	10,300 (56.0)	9400 (60.4)	7850 (63.3)
65					8700 (23.9)	8900 (38.0)	9050 (46.6)	9200 (52.5)	8850 (57.5)	7000 (60.6)
70					*4650 (9.2)	7650 (31.8)	7850 (42.1)	7950 (48.7)	8100 (54.4)	6300 (57.9)
75						6600 (24.3)	6750 (37.2)	6900 (44.8)	7000 (51.0)	5700 (55.0)
80						*4400 (12.8)	5850 (31.6)	6,000 (40.5)	6100 (47.5)	5150 (52.1)
85							5100 (24.9)	5200 (35.8)	5300 (43.8)	4650 (49.0)
90							*3850 (15.3)	4500 (30.5)	4600 (39.8)	4150 (45.7)
95								3900 (24.1)	4000 (35.5)	3700 (42.2)
100								*2800 (14.9)	3450 (30.5)	3300 (38.4)
105									2950 (24.7)	3000 (34.3)
110									*2400 (16.8)	2600 (29.5)
115										*1900 (23.7)
120										*1100 (15.8)
Minimum boom angle (°) for indicated length (no load)							0	5	8	10
Maximum boom length (ft.) at 0° boom angle (no load)							97			

NOTE: ( ) Boom angles are in degrees.

\*Loads are structurally limited.

#LMI operating code. Refer to LMI manual for operating instructions.

Lifting capacities at zero degree boom angle										
Boom angle	Main boom length in feet									
	31.7	43-A	54-B	64-C	75-D	86-E				
0°	12,900 (27.5)	7600 (38.8)	4850 (19.8)	3700 (59.8)	2200 (70.8)	1150 (81.8)				

NOTE: ( ) Reference radii in feet.

80034849A



PORTLAND OFFICE: 503.283.3111  
SEATTLE OFFICE: 206.784.1054

WWW.NESSCAMPBELL.COM

# Load chart

**NBT50/55**



39,0 m  
(128 ft)



Jib Stowed



1361 kg  
(3000 lb)



100%

Outriggers



Over Rear

Radius in feet	#0004									
	Main boom length in feet									
	31.7	43-A	54-B	64-C	75-D	86-E	97-F	107-G	118-H	128
8	98,850 (68.1)									
10	91,100 (64.0)	39,250 (71.3)								
12	78,950 (59.8)	39,250 (68.5)	39,250 (73.3)							
15	62,300 (53.1)	39,250 (64.0)	39,250 (69.9)	39,250 (73.5)						
20	45,150 (40.2)	39,250 (56.2)	39,250 (64.2)	39,250 (68.8)	33,650 (72.5)					
25	30,500 (21.8)	35,700 (47.5)	36,350 (57.9)	36,650 (63.9)	29,650 (68.4)	22,250 (71.5)				
30		28,150 (37.3)	28,800 (51.2)	29,200 (58.6)	26,650 (64.2)	20,000 (68.0)	17,450 (71.2)			
35		21,500 (23.6)	23,400 (43.8)	23,800 (53.0)	24,100 (59.8)	18,100 (64.3)	15,950 (68.0)	14,400 (70.8)	12,600 (73.2)	
40			19,400 (35.2)	19,800 (47.0)	20,100 (55.1)	16,650 (60.5)	14,750 (64.8)	13,350 (68.0)	11,750 (70.8)	10,600 (73.0)
45			15,800 (24.0)	16,300 (40.3)	16,600 (50.0)	15,400 (56.5)	13,650 (61.5)	12,250 (65.0)	11,000 (68.2)	10,000 (70.8)
50				13,400 (32.4)	13,700 (44.6)	13,950 (52.3)	12,500 (58.0)	11,450 (62.0)	10,350 (65.8)	9,400 (68.4)
55				11,150 (22.2)	11,450 (38.6)	11,700 (47.8)	11,650 (54.4)	10,650 (59.2)	9,700 (63.2)	8,500 (65.9)
60					9,750 (32.4)	10,000 (43.3)	10,200 (50.8)	10,000 (56.0)	9,100 (60.4)	7,600 (63.3)
65					8,250 (23.9)	8,500 (38.0)	8,700 (46.6)	8,900 (52.5)	8,550 (57.5)	6,750 (60.6)
70					*4200 (9.2)	7,250 (31.8)	7,500 (42.1)	7,650 (48.7)	7,800 (54.4)	6,050 (57.9)
75						6,200 (24.3)	6,400 (37.2)	6,600 (44.8)	6,700 (51.0)	5,450 (55.0)
80							*4000 (12.8)	5,500 (31.6)	5,700 (40.5)	4,900 (52.1)
85								4,750 (24.9)	4,900 (35.8)	5,000 (43.8)
90								*3500 (15.3)	4,200 (30.5)	4,300 (39.8)
95									3,600 (24.1)	3,700 (35.5)
100									*2500 (14.9)	3,150 (30.5)
105										2,650 (24.7)
110										*2100 (16.8)
115										*1650 (23.7)
120										*850 (15.8)
Minimum boom angle (°) for indicated length (no load)							0	5	8	10
Maximum boom length (ft) at 0° boom angle (no load)							97			

NOTE: ( ) Boom angles are in degrees.

\*Loads are structurally limited.

#LMI operating code. Refer to LMI manual for operating instructions.

Boom angle	Lifting capacities at zero degree boom angle									
	Main boom length in feet									
	31.7	43-A	54-B	64-C	75-D	86-E				
0°	11,750 (27.5)	6,800 (38.8)	4,250 (19.8)	3,200 (59.8)	1,750 (70.8)	750 (81.8)				

NOTE: ( ) Reference radii in feet.

80034850A



PORTLAND OFFICE: 503.283.3111  
SEATTLE OFFICE: 206.784.1054

WWW.NESSCAMPBELL.COM

# Load chart

**NBT50/55**



7,9 m - 13,7 m  
(26 ft - 45 ft)



1361 kg  
(3000 lb)



Outriggers



360°

Radius in feet	26 ft LENGTH		45 ft LENGTH	
	#0005 or #1005	#0007 or #1007	#0009 or #1009	#0011 or #1011
	0° OFFSET	30° OFFSET	0° OFFSET	30° OFFSET
50	6000 (72.6)			
55	5800 (70.8)			
60	5500 (69.0)			
65	5200 (67.0)	4900 (72.1)	4050 (70.4)	
70	4850 (65.0)	4650 (69.9)	4000 (68.8)	
75	4500 (62.9)	4400 (67.7)	3950 (67.2)	2800 (73.8)
80	4250 (60.8)	4150 (65.4)	3900 (65.6)	2700 (71.9)
85	3950 (58.6)	4000 (63.1)	3800 (63.9)	2650 (70.0)
90	3600 (56.2)	3800 (60.7)	3550 (62.0)	2600 (68.0)
95	3000 (53.6)	3550 (58.2)	3250 (59.9)	2550 (66.0)
100	2450 (50.9)	2950 (55.3)	3000 (57.8)	2500 (63.9)
105	2,000 (48.2)	2450 (51.5)	2700 (55.6)	2450 (61.8)
110	1600 (45.3)	1950 (49.1)	2400 (53.3)	2400 (59.5)
115	1200 (42.2)	1500 (45.8)	2000 (50.8)	2350 (57.2)
120	850 (39.0)	1100 (42.4)	1650 (48.3)	2200 (54.6)
125	550 (35.6)	750 (38.6)	1300 (45.6)	1800 (51.6)
130			1000 (42.8)	1450 (48.5)
135			700 (39.8)	1050 (45.2)
140			450 (36.7)	800 (41.7)
145				500 (37.9)
Min. boom angle for indicated length (no load)	34°	34°	36°	36°
Max. boom length at 0° boom angle (no load)	64 ft		64 ft	

NOTE: ( ) Boom angles are in degrees. 80034857B

#LMI operating code. Refer to LMI manual for instructions.

**Boom extension capacity notes:**

- All capacities above the bold line are based on structural strength limitations.
  - 26 ft and 45 ft extension lengths may be used for single line lifting service.
  - Radii listed are for a fully extended boom with the boom extension erected. For main boom lengths less than fully extended, the rated loads are determined by boom angle. Use only the column which corresponds to the boom extension length and offset for which the machine is configured. For boom angles not shown, use the rating of the next lower boom angle.
- Warning:** Operation of this machine with heavier loads than the capacities listed is strictly prohibited. Machine tipping with boom extension occurs rapidly and without advance warning.
- Boom angle is the angle above or below horizontal of the longitudinal axis of the boom base section after lifting rated load.
  - Capacities listed are with outriggers properly extended and vertical jacks set only.



PORTLAND OFFICE: 503.283.3111  
SEATTLE OFFICE: 206.784.1054  
[WWW.NESSCAMPBELL.COM](http://WWW.NESSCAMPBELL.COM)

# Load chart

**NBT50/55**



7,9 m - 13,7 m  
(26 ft - 45 ft)



1361 kg  
(3000 lb)



100%



Over Rear

Radius in feet	26 ft LENGTH		45 ft LENGTH	
	#0006	#0008	#0010	#0012
	0° OFFSET	30° OFFSET	0° OFFSET	30° OFFSET
50	6000 (72.6)			
55	5800 (70.8)			
60	5500 (69.0)			
65	5200 (67.0)	4900 (72.1)	4050 (70.4)	
70	4850 (65.0)	4650 (69.9)	4000 (68.8)	
75	4500 (62.9)	4400 (67.7)	3950 (67.2)	2800 (73.8)
80	4250 (60.8)	4150 (65.4)	3900 (65.6)	2700 (71.9)
85	3950 (58.6)	4000 (63.1)	3800 (63.9)	2650 (70.0)
90	3800 (56.4)	3800 (60.7)	3550 (62.0)	2600 (68.0)
95	3650 (54.1)	3650 (58.3)	3250 (59.9)	2550 (66.0)
100	3150 (51.5)	3350 (55.6)	3000 (57.8)	2500 (63.9)
105	2600 (48.6)	2900 (52.6)	2700 (55.6)	2450 (61.8)
110	2100 (45.7)	2550 (49.6)	2500 (53.5)	2400 (59.5)
115	1700 (42.6)	2150 (46.3)	2300 (51.2)	2350 (57.2)
120	1350 (39.4)	1650 (42.8)	2050 (48.7)	2300 (54.7)
125	950 (35.9)	1200 (39.0)	1750 (46.1)	2250 (52.1)
130	650 (32.1)	850 (34.8)	1500 (43.4)	2100 (49.2)
135		450 (30.0)	1200 (40.4)	1700 (45.8)
140			900 (37.3)	*1350 (42.3)
145			650 (33.9)	*900 (38.3)
150				*600 (33.9)
Min. boom angle for indicated length (no load)	29°	30°	30°	31°
Max. boom length at 0° boom angle (no load)	64 ft		64 ft	

NOTE: ( ) Boom angles are in degrees. 80034858A

#LMI operating code. Refer to LMI manual for instructions.

\*Capacities are structurally limited.

### Boom extension capacity notes:

- All capacities above the bold line are based on structural strength limitations.
  - 26 ft and 45 ft extension lengths may be used for single line lifting service.
  - Radii listed are for a fully extended boom with the boom extension erected. For main boom lengths less than fully extended, the rated loads are determined by boom angle. Use only the column which corresponds to the boom extension length and offset for which the machine is configured. For boom angles not shown, use the rating of the next lower boom angle.
- Warning:** Operation of this machine with heavier loads than the capacities listed is strictly prohibited. Machine tipping with boom extension occurs rapidly and without advance warning.
- Boom angle is the angle above or below horizontal of the longitudinal axis of the boom base section after lifting rated load.
  - Capacities listed are with outriggers properly extended and vertical jacks set only.



PORTLAND OFFICE: 503.283.3111  
SEATTLE OFFICE: 206.784.1054  
[WWW.NESSCAMPBELL.COM](http://WWW.NESSCAMPBELL.COM)

# Load chart

## NBT50/55



39,0 m  
(128 ft)



0 kg  
(0 lb)

Counterweight



100%

Outriggers



360°

Radius in feet	#8001									
	Main boom length in feet									
	31.7	43-A	54-B	64-C	75-D	86-E	97-F	107-G	118-H	128
8	100,000 (68.1)									
10	92,100 (64.0)	40,050 (71.3)								
12	76,600 (59.8)	40,050 (68.5)	40,350 (73.3)							
15	60,600 (53.1)	40,050 (64.0)	40,350 (69.9)	40,300 (73.5)						
20	44,100 (40.2)	40,050 (56.2)	40,350 (64.2)	40,300 (68.8)	34,100 (72.5)					
25	31,650 (21.8)	34,250 (47.5)	34,750 (57.9)	35,050 (63.9)	30,100 (68.4)	22,650 (71.5)				
30		26,750 (37.3)	27,450 (51.2)	27,800 (58.6)	27,100 (64.2)	20,400 (68.0)	17,800 (71.2)			
35		19,550 (23.6)	20,200 (43.8)	20,550 (52.9)	20,900 (59.6)	18,500 (64.3)	16,300 (68.0)	14,700 (70.8)	12,900 (73.2)	
40			15,450 (35.1)	15,800 (46.9)	16,100 (54.9)	16,350 (60.5)	15,100 (64.8)	13,650 (68.0)	12,050 (70.8)	10,850 (73.0)
45			12,150 (23.9)	12,500 (40.1)	12,800 (49.8)	13,000 (56.3)	13,200 (61.4)	12,550 (65.0)	11,300 (68.2)	10,250 (70.8)
50				10,200 (33.1)	10,450 (45.0)	10,650 (52.5)	10,850 (58.1)	11,050 (61.9)	10,650 (65.8)	9650 (68.4)
55				8300 (23.3)	8550 (39.0)	8750 (47.9)	8950 (54.3)	9100 (58.9)	9250 (63.0)	8750 (65.9)
60					7050 (32.2)	7250 (43.1)	7400 (50.4)	7550 (55.4)	7700 (59.9)	7800 (63.3)
65					5800 (23.7)	6000 (37.7)	6150 (46.2)	6300 (51.9)	6400 (56.8)	6550 (60.5)
70					*4650 (9.2)	5000 (31.6)	5150 (41.7)	5250 (48.1)	5350 (53.6)	5450 (57.6)
75						4100 (24.0)	4250 (36.8)	4400 (44.2)	4500 (50.3)	4600 (54.6)
80						3400 (12.7)	3550 (31.2)	3650 (39.9)	3750 (46.8)	3800 (51.6)
85							2900 (24.5)	3000 (35.3)	3100 (43.1)	3150 (48.4)
90							2350 (15.0)	2450 (30.0)	2550 (39.1)	2600 (45.0)
95								1950 (23.6)	2050 (34.8)	2100 (41.5)
100								1500 (14.6)	1600 (29.9)	1650 (37.7)
105									1200 (24.0)	1250 (33.5)
110									850 (16.2)	900 (28.7)
115										600 (23.1)
Minimum boom angle (°) at indicated length (no load)							0	5	8	17
Maximum boom length (ft.) at 0° boom angle (no load)							97			

NOTE: ( ) Boom angles are in degrees.

\*Loads are structurally limited.

#LMI operating code. Refer to LMI manual for operating instructions.

Lifting capacities at zero degree boom angle										
Boom angle	Main boom length in feet									
	31.7	43-A	54-B	64-C	75-D	86-E				
0°	12,900 (27.5)	7600 (38.8)	4850 (19.8)	3700 (59.8)	2200 (70.8)	1150 (81.8)				

NOTE: ( ) Reference radii in feet.

80034955



PORTLAND OFFICE: 503.283.3111  
SEATTLE OFFICE: 206.784.1054

WWW.NESSCAMPBELL.COM



# Load chart

**NBT50/55**



39,0 m  
(128 ft)



Jib Stowed



0 kg  
(0 lb)

Counterweight



100%

Outriggers



360°

Radius in feet	#8002									
	Main boom length in feet									
	31.7	43-A	54-B	64-C	75-D	86-E	97-F	107-G	118-H	128
8	98,850 (68.1)									
10	90,950 (64.0)	39,250 (71.3)								
12	75,450 (59.8)	39,250 (68.5)	39,250 (73.3)							
15	59,450 (53.1)	39,250 (64.0)	39,250 (69.9)	39,250 (73.5)						
20	42,950 (40.2)	39,250 (56.2)	39,250 (64.2)	39,250 (68.8)	33,650 (72.5)					
25	30,500 (21.8)	33,450 (47.5)	34,150 (57.9)	34,550 (63.9)	29,650 (68.4)	22,250 (71.5)				
30		25,950 (37.3)	26,850 (51.2)	27,300 (58.6)	26,650 (64.2)	20,000 (68.0)	17,450 (71.2)			
35		18,750 (23.6)	19,600 (43.8)	20,050 (52.9)	20,450 (59.6)	18,100 (64.3)	15,950 (68.0)	14,400 (70.8)	12,600 (73.2)	
40			14,850 (35.1)	15,300 (46.9)	15,650 (54.9)	15,950 (60.5)	14,750 (64.8)	13,350 (68.0)	11,750 (70.8)	10,600 (73.0)
45			11,550 (23.9)	12,000 (40.1)	12,350 (49.8)	12,600 (56.3)	12,850 (61.4)	12,250 (65.0)	11,000 (68.2)	10,000 (70.8)
50				9700 (33.1)	10,000 (45.0)	10,250 (52.5)	10,500 (58.1)	10,750 (61.9)	10,350 (65.8)	9400 (68.4)
55				7800 (23.3)	8100 (39.0)	8350 (47.9)	8600 (54.3)	8800 (58.9)	8950 (63.0)	8500 (65.9)
60					6600 (32.2)	6850 (43.1)	7050 (50.4)	7250 (55.4)	7400 (59.9)	7550 (63.3)
65					5350 (23.7)	5600 (37.7)	5800 (46.2)	6000 (51.9)	6100 (56.8)	6300 (60.5)
70					*4200 (9.2)	4600 (31.6)	4800 (41.7)	4950 (48.1)	5050 (53.6)	5200 (57.6)
75						3700 (24.0)	3900 (36.8)	4100 (44.2)	4200 (50.3)	4350 (54.6)
80						3000 (12.7)	3200 (31.2)	3350 (39.9)	3450 (46.8)	3550 (51.6)
85							2550 (24.5)	2700 (35.3)	2800 (43.1)	2900 (48.4)
90							2000 (15.0)	2150 (30.0)	2250 (39.1)	2350 (45.0)
95								1650 (23.6)	1750 (34.8)	1850 (41.5)
100								1200 (14.6)	1300 (29.9)	1400 (37.7)
105									900 (24.0)	1000 (33.5)
110									550 (16.2)	650 (28.7)
Minimum boom angle (°) for indicated length (no load)							0	5	8	17
Maximum boom length (ft) at 0° boom angle (no load)							97			

NOTE: ( ) Boom angles are in degrees.

\*Loads are structurally limited.

#LMI operating code. Refer to LMI manual for operating instructions.

Boom angle	Lifting capacities at zero degree boom angle									
	Main boom length in feet									
	31.7	43-A	54-B	64-C	75-D	86-E				
0°	11,750 (27.5)	6,800 (38.8)	4,250 (19.8)	3,200 (59.8)	1,750 (70.8)	750 (81.8)				

NOTE: ( ) Reference radii in feet.

80034956



PORTLAND OFFICE: 503.283.3111  
SEATTLE OFFICE: 206.784.1054

WWW.NESSCAMPBELL.COM

# Load chart

**NBT50/55**



39,0 m  
(128 ft)



0 kg  
(0 lb)



Outriggers

100%



Over Rear

Radius in feet	#8003									
	Main boom length in feet									
	31.7	43-A	54-B	64-C	75-D	86-E	97-F	107-G	118-H	128
8	100,000 (68.1)									
10	92,100 (64.0)	40,050 (71.3)								
12	76,600 (59.8)	40,050 (68.5)	40,350 (73.3)							
15	60,600 (53.1)	40,050 (64.0)	40,350 (69.9)	40,300 (73.5)						
20	44,100 (40.2)	40,050 (56.2)	40,350 (64.2)	40,300 (68.8)	34,100 (72.5)					
25	31,650 (21.8)	34,250 (47.5)	34,750 (57.9)	35,050 (63.9)	30,100 (68.4)	22,650 (71.5)				
30		27,050 (37.3)	27,500 (51.2)	27,800 (58.6)	27,100 (64.2)	20,400 (68.0)	17,800 (71.2)			
35		21,750 (23.6)	22,350 (43.8)	22,650 (53.0)	22,900 (59.7)	18,500 (64.3)	16,300 (68.0)	14,700 (70.8)	12,900 (73.2)	
40			17,550 (35.2)	17,900 (46.9)	18,150 (54.9)	17,050 (60.5)	15,100 (64.8)	13,650 (68.0)	12,050 (70.8)	10,850 (73.0)
45			14,100 (24.0)	14,450 (40.2)	14,700 (49.9)	14,900 (56.5)	14,000 (61.5)	12,550 (65.0)	11,300 (68.2)	10,250 (70.8)
50				11,850 (32.3)	12,100 (44.5)	12,300 (52.2)	12,450 (57.9)	11,750 (62.0)	10,650 (65.8)	9650 (68.4)
55				9950 (23.3)	10,200 (39.1)	10,400 (48.1)	10,550 (54.5)	10,700 (59.1)	10,000 (63.2)	8750 (65.9)
60					8550 (32.3)	8750 (43.2)	8900 (50.6)	9050 (55.7)	9200 (60.3)	7850 (63.3)
65					7250 (23.8)	7400 (37.8)	7550 (46.4)	7700 (52.2)	7850 (57.2)	7000 (60.6)
70					*4650 (9.2)	6300 (31.7)	6450 (41.9)	6550 (48.4)	6700 (54.0)	6300 (57.9)
75						5350 (24.2)	5500 (37.0)	5600 (44.5)	5750 (50.7)	5700 (55.0)
80						*4400 (12.8)	4700 (31.4)	4800 (40.2)	4900 (47.2)	5000 (52.0)
85							4000 (24.7)	4100 (35.5)	4200 (43.5)	4300 (48.8)
90							3350 (15.2)	3450 (30.2)	3550 (39.5)	3650 (45.5)
95								2900 (23.8)	3000 (35.1)	3100 (41.9)
100								2450 (14.8)	2550 (30.2)	2600 (38.1)
105									2100 (24.4)	2150 (33.9)
110									1700 (16.5)	1750 (29.1)
115										1400 (23.5)
120										*1100 (15.8)
Minimum boom angle (°) for indicated length (no load)							0	5	8	10
Maximum boom length (ft) at 0° boom angle (no load)							97			

NOTE: ( ) Boom angles are in degrees.  
 \*Loads are structurally limited.  
 #LMI operating code. Refer to LMI manual for operating instructions.

Boom angle	Lifting capacities at zero degree boom angle									
	Main boom length in feet									
	31.7	43-A	54-B	64-C	75-D	86-E				
0°	12,900 (27.5)	7600 (38.8)	4850 (19.8)	3700 (59.8)	2200 (70.8)	1150 (81.8)				

NOTE: ( ) Reference radii in feet. 80034959



PORTLAND OFFICE: 503.283.3111  
 SEATTLE OFFICE: 206.784.1054  
[WWW.NESSCAMPBELL.COM](http://WWW.NESSCAMPBELL.COM)

# Load chart

**NBT50/55**



39,0 m  
(128 ft)



Jib Stowed



0 kg  
(0 lb)

Counterweight



100%

Outriggers



Over Rear

Radius in feet	#8004									
	Main boom length in feet									
	31.7	43-A	54-B	64-C	75-D	86-E	97-F	107-G	118-H	128
8	98,850 (68.1)									
10	90,950 (64.0)	39,250 (71.3)								
12	75,450 (59.8)	39,250 (68.5)	39,250 (73.3)							
15	59,450 (53.1)	39,250 (64.0)	39,250 (69.9)	39,250 (73.5)						
20	42,950 (40.2)	39,250 (56.2)	39,250 (64.2)	39,250 (68.8)	33,650 (72.5)					
25	30,500 (21.8)	33,450 (47.5)	34,150 (57.9)	34,550 (63.9)	29,650 (68.4)	22,250 (71.5)				
30		26,250 (37.3)	26,900 (51.2)	27,300 (58.6)	26,650 (64.2)	20,000 (68.0)	17,450 (71.2)			
35		20,950 (23.6)	21,750 (43.8)	22,150 (53.0)	22,450 (59.7)	18,100 (64.3)	15,950 (68.0)	14,400 (70.8)	12,600 (73.2)	
40			16,950 (35.2)	17,400 (46.9)	17,700 (54.9)	16,650 (60.5)	14,750 (64.8)	13,350 (68.0)	11,750 (70.8)	10,600 (73.0)
45			13,500 (24.0)	13,950 (40.2)	14,250 (49.9)	14,500 (56.5)	13,650 (61.5)	12,250 (65.0)	11,000 (68.2)	10,000 (70.8)
50				11,350 (32.3)	11,650 (44.5)	11,900 (52.2)	12,100 (57.9)	11,450 (62.0)	10,350 (65.8)	9,400 (68.4)
55				9,450 (23.3)	9,750 (39.1)	10,000 (48.1)	10,200 (54.5)	10,400 (59.1)	9,700 (63.2)	8,500 (65.9)
60					8,100 (32.3)	8,350 (43.2)	8,550 (50.6)	8,750 (55.7)	8,900 (60.3)	7,600 (63.3)
65					6,800 (23.8)	7,000 (37.8)	7,200 (46.4)	7,400 (52.2)	7,550 (57.2)	6,750 (60.6)
70					*4,200 (9.2)	5,900 (31.7)	6,100 (41.9)	6,250 (48.4)	6,400 (54.0)	6,050 (57.9)
75						4,950 (24.2)	5,150 (37.0)	5,300 (44.5)	5,450 (50.7)	5,450 (55.0)
80						*4,000 (12.8)	4,350 (31.4)	4,500 (40.2)	4,600 (47.2)	4,750 (52.0)
85							3,650 (24.7)	3,800 (35.5)	3,900 (43.5)	4,050 (48.8)
90							3,000 (15.2)	3,150 (30.2)	3,250 (39.5)	3,400 (45.5)
95								2,600 (23.8)	2,700 (35.1)	2,850 (41.9)
100								2,150 (14.8)	2,250 (30.2)	2,350 (38.1)
105									1,800 (24.4)	1,900 (33.9)
110									1,400 (16.5)	1,500 (29.1)
115										1,150 (23.5)
120										*850 (15.8)
Minimum boom angle (°) for indicated length (no load)							0	5	8	10
Maximum boom length (ft.) at 0° boom angle (no load)							97			

NOTE: ( ) Boom angles are in degrees.

\*Loads are structurally limited.

#LMI operating code. Refer to LMI manual for operating instructions.

Lifting capacities at zero degree boom angle										
Boom angle	Main boom length in feet									
	31.7	43-A	54-B	64-C	75-D	86-E				
0°	11,750 (27.5)	6,800 (38.8)	4,250 (19.8)	3,200 (59.8)	1,750 (70.8)	750 (81.8)				

NOTE: ( ) Reference radii in feet.

80034960



PORTLAND OFFICE: 503.283.3111  
SEATTLE OFFICE: 206.784.1054

WWW.NESSCAMPBELL.COM

# Load chart

**NBT50/55**



7,9 m - 13,7 m  
(26 ft - 45 ft)



0 kg  
(0 lb)

Counterweight



Outriggers



360°

100%

Radius in feet	26 ft LENGTH		45 ft LENGTH	
	#8005	#8007	#8009	#8011
	0° OFFSET	30° OFFSET	0° OFFSET	30° OFFSET
50	6000 (72.6)			
55	5800 (70.8)			
60	5500 (69.0)			
65	5200 (67.0)	4900 (72.1)	4050 (70.4)	
70	4850 (65.0)	4650 (69.9)	4000 (68.8)	
75	4500 (62.9)	4400 (67.7)	3950 (67.2)	2800 (73.8)
80	3700 (60.5)	4150 (65.4)	3900 (65.6)	2700 (71.9)
85	3000 (58.0)	3750 (63.0)	3800 (63.9)	2650 (70.0)
90	2400 (55.4)	3050 (60.2)	3350 (61.8)	2600 (68.0)
95	1900 (52.8)	2400 (57.3)	2750 (59.4)	2550 (66.0)
100	1450 (50.2)	1950 (54.5)	2250 (57.1)	2500 (63.9)
105	1000 (47.4)	1450 (51.5)	1800 (54.7)	2450 (61.8)
110	650 (44.5)	1000 (48.4)	1450 (52.3)	2200 (59.3)
115		650 (45.2)	1100 (49.8)	1750 (56.5)
120			750 (47.2)	1350 (53.7)
125			450 (44.5)	1000 (50.7)
130				650 (47.7)
Min. boom angle for indicated length (no load)	43°	43°	44°	45°
Max. boom length at 0° boom angle (no load)	64 ft		64 ft	

NOTE: ( ) Boom angles are in degrees.

80034967

#LMI operating code. Refer to LMI manual for instructions.

## Boom extension capacity notes:

- All capacities above the bold line are based on structural strength limitations.
  - 26 ft and 45 ft extension lengths may be used for single line lifting service.
  - Radii listed are for a fully extended boom with the boom extension erected. For main boom lengths less than fully extended, the rated loads are determined by boom angle. Use only the column which corresponds to the boom extension length and offset for which the machine is configured. For boom angles not shown, use the rating of the next lower boom angle.
- Warning:** Operation of this machine with heavier loads than the capacities listed is strictly prohibited. Machine tipping with boom extension occurs rapidly and without advance warning.
- Boom angle is the angle above or below horizontal of the longitudinal axis of the boom base section after lifting rated load.
  - Capacities listed are with outriggers properly extended and vertical jacks set only.



PORTLAND OFFICE: 503.283.3111  
SEATTLE OFFICE: 206.784.1054

[WWW.NESSCAMPBELL.COM](http://WWW.NESSCAMPBELL.COM)

# Load chart

**NBT50/55**



7,9 m - 13,7 m  
(26 ft - 45 ft)



0 kg  
(0 lb)



Outriggers

100%



Over Rear

Radius in feet	26 ft LENGTH		45 ft LENGTH	
	#8006	#8008	#8010	#8012
	0° OFFSET	30° OFFSET	0° OFFSET	30° OFFSET
50	6000 (72.6)			
55	5800 (70.8)			
60	5500 (69.0)			
65	5200 (67.0)	4900 (72.1)	4050 (70.4)	
70	4850 (65.0)	4650 (69.9)	4000 (68.8)	
75	4500 (62.9)	4400 (67.7)	3950 (67.2)	2800 (73.8)
80	4250 (60.8)	4150 (65.4)	3900 (65.6)	2700 (71.9)
85	3950 (58.6)	4000 (63.1)	3800 (63.9)	2650 (70.0)
90	3450 (56.1)	3800 (60.7)	3550 (62.0)	2600 (68.0)
95	2900 (53.6)	3450 (58.1)	3250 (59.9)	2550 (66.0)
100	2400 (50.9)	2850 (55.2)	3000 (57.8)	2500 (63.9)
105	1900 (48.1)	2350 (52.2)	2700 (55.6)	2450 (61.8)
110	1500 (45.2)	1950 (49.1)	2300 (53.2)	2400 (59.5)
115	1150 (42.2)	1450 (45.8)	1900 (50.7)	2350 (57.2)
120	800 (39.0)	1050 (42.3)	1550 (48.1)	2150 (54.5)
125	500 (35.5)	700 (38.6)	1250 (45.5)	1750 (51.5)
130		400 (34.5)	950 (42.7)	1400 (48.5)
135			650 (39.7)	1050 (45.2)
140			450 (36.7)	750 (41.7)
145				450 (37.9)
Min. boom angle for indicated length (no load)	34°	34°	36°	37°
Max. boom length at 0° boom angle (no load)	64 ft		64 ft	

NOTE: ( ) Boom angles are in degrees.

80034968

#LMI operating code. Refer to LMI manual for instructions.

\*Capacities are structurally limited.

## Boom extension capacity notes:

- All capacities above the bold line are based on structural strength limitations.
  - 26 ft and 45 ft extension lengths may be used for single line lifting service.
  - Radii listed are for a fully extended boom with the boom extension erected. For main boom lengths less than fully extended, the rated loads are determined by boom angle. Use only the column which corresponds to the boom extension length and offset for which the machine is configured. For boom angles not shown, use the rating of the next lower boom angle.
- Warning:** Operation of this machine with heavier loads than the capacities listed is strictly prohibited. Machine tipping with boom extension occurs rapidly and without advance warning.
- Boom angle is the angle above or below horizontal of the longitudinal axis of the boom base section after lifting rated load.
  - Capacities listed are with outriggers properly extended and vertical jacks set only.



PORTLAND OFFICE: 503.283.3111  
SEATTLE OFFICE: 206.784.1054

[WWW.NESSCAMPBELL.COM](http://WWW.NESSCAMPBELL.COM)