

BOOM TRUCK 33 TONS

NATIONAL SERIES 14100H

BOOM LENGTHS:
30 TO 100 FT

JIB LENGTHS:
30 TO 54 FT

JIB OFFSETS:
0



NOTES:

National Crane Series 1400H

Product Guide



Features

- 29,9 t (33 USt) rating
- 38,72 m (127 ft) five-section boom
- Self-lubricating Easy Glide wear pads
- Internal anti-two-block



Features

National Crane 1400H

- 29,9 t (33 USt) maximum capacity
 - 50,3 m (165 ft) maximum vertical reach*
 - 41,15 m (135 ft) maximum vertical hydraulic reach
- *Maximum vertical reach is ground-level to boom tip height at maximum extension and angle with outriggers/stabilizers full extended.

Five-section boom

At 38,72 m (127 ft), the Series 1400H five-section boom is the longest in its size range. The long boom allows the operator to perform more lifts without the use of a jib, reducing setup time and improving efficiency. A 30,5 m (100 ft) four-section boom or a 21,03 m (69 ft) four-section boom is also available.



Easy Glide boom wear pads

Easy Glide boom wear pads reduce the conditions that cause boom chatter resulting in smoother crane operation.

Overload protection

All National Crane boom trucks are equipped with overload protection. A Load Moment Indicator (LMI) is standard on all Series 1400H machines. The LMI display console is weatherproof. The LCD display is visible in full or low light and displays all crane load lifting values simultaneously.



Outriggers

Mainframe outriggers are crossframe H-style, with 7,47 m (24 ft 6 in) span, with a mid-span setting of 5,64 m (18 ft 6 in). Rear stabilizers are H-style with 5,64 m (18 ft 6 in) span. Removable ball and socket aluminum outrigger pads are included on mainframe outriggers.



PORTLAND OFFICE: 503.283.3111
SEATTLE OFFICE: 206.784.1054
WWW.NESSCAMPBELL.COM

Features

Best in class performance and serviceability

- The stronger standard torsion box improves rigidity, reduces truck frame flex and reduces the need for counterweight
- Speedy-reeve boom tip and sheave blocks simplify rigging changes by decreasing the time needed to change line reeving
- Crane components painted before assembly reduce the chance of rust, improve serviceability and enhance the appearance of the crane
- Internal anti-two block wiring standard on the 1400H routes the wiring through the inside of the boom eliminating the possibility of snagging the wire on obstructions
- Bearings on the boom and retract cables can be greased through access holes in the boom side plates and number of internal boom parts has been reduced improving serviceability
- The Series 1400H is supplied with 375° non-continuous rotation standard
- Adjustable swing speed comes standard on the 1400H. A control knob located on the swing motor brake release valve can be easily adjusted to the crane operator's swing speed preference
- Radiator mounted on truck frame with electric fan is standard



PORTLAND OFFICE: 503.283.3111
SEATTLE OFFICE: 206.784.1054
WWW.NESSCAMPBELL.COM

Mounting configuration

The mounting configuration shown is based on the Series 1400H with an 85% stability factor. The complete unit must be installed in accordance with factory requirements and a test performed to determine actual stability and counterweight requirements since individual truck chassis vary. If bare truck weights are not met, counterweight will be required. Chassis must be equipped with a front frame extension suitable for SFO addition. Contact factory for complete chassis specifications.

Working area	360°
Gross Axle Weight Rating Front.....	9072 kg (20,000 lb)*
Gross Axle Weight Rating Rear.....	18 144 kg (40,000 lb)*
Gross Vehicle Weight Rating	27 216 kg (60,000 lb)*
Wheelbase.....	Minimum 681 cm (268 in)
Cab to Axle/trunnion (CA/CT)	Minimum 518 cm (204 in)
After Frame (AF).....	305 cm (120 in) minimum
Frame Section Modulus (SM), front axle to end of afterframe, with (758 MPa 110,000 PSI).....	492 cm ³ (30 in ³)
Stability Weight, Front	4196 kg (9250 lb) minimum**
Stability Weight, Rear.....	3674 kg (8100 lb) minimum**
Estimated Average Final Weight	23 360 kg (51,500 lb)**

The diagram shows the 360° working area that can be achieved with the front stabilizer (optional on the Series 1400H). The front stabilizer is required when extending the boom and lifting loads forward of the outriggers. A minimum of 164 cm³ (10 in³) section modulus at 759 MPa (110,000 psi) is required from the rear of the front spring hanger forward to the front stabilizer. Integral front frame extension required.

* Required to mount basic crane with 9,15 m (30 ft) jib option. Additional options or heavier bare chassis weights will require additional axles or a GVWR in excess of 27 216 kg (60,000 lb); in some states, special permits for overload are required.

** Estimated axle scale weights prior to installation of crane, stabilizers and subbase for 85% stability.

*** Includes basic crane without jib, 379 L (100 gal) fuel tank, 22 ft wood flatbed, hydraulic pump and PTO, rear bumper, rear stabilizer, boom rest, and two workers, 136 kg (300 lb) in cab.

Note: Chassis will require integral extended front frame rails for SFO addition.

Truck requirements

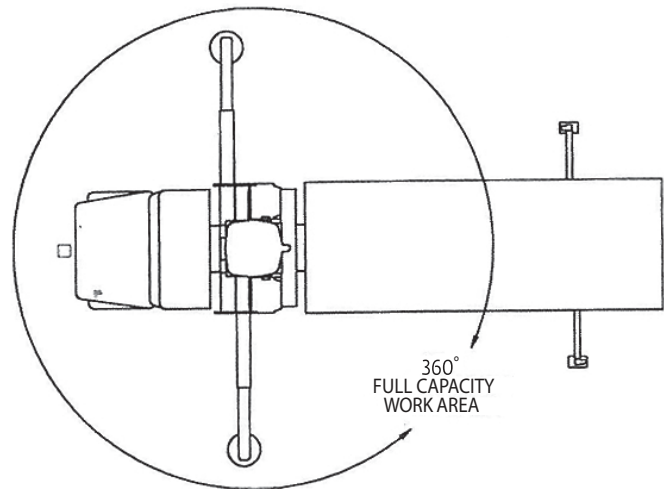
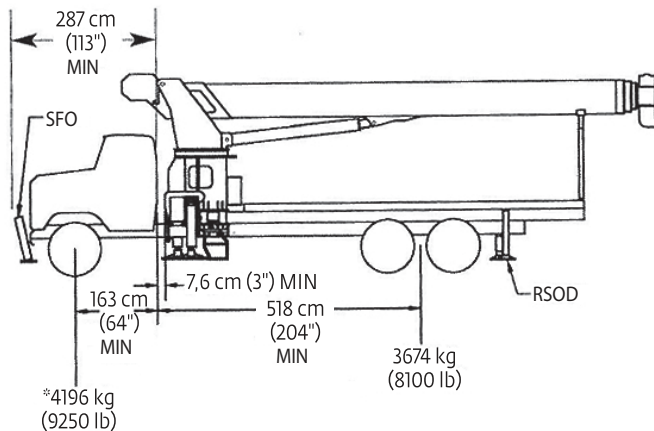

Notes:

- Gross Vehicle Weight Rating (GVWR) is dependent on all components of the vehicle (axles, tires, springs, frame, etc.) meeting manufacturers' recommendations; always specify GVWR when purchasing trucks.
- Diesel engines require a variable speed governor and energize-to-run fuel solenoid for smooth crane operation. Electronic fuel-injected engines are required.
- All mounting data is based on a National Series 1400H with the standard subbase and an 85% stability factor.
- The complete unit must be installed in accordance with factory requirements, and a test performed to determine actual stability and counterweight requirements per SAE J765; contact the factory for details.
- Transmission neutral safety interlock switch is required.



PORTLAND OFFICE: 503.283.3111
 SEATTLE OFFICE: 206.784.1054
WWW.NESSCAMPBELL.COM

Specifications

Boom and jib combinations data

Available in three basic models.

Model 1469H — Equipped with a 7,01 m - 21,03 m (23 ft - 69 ft) four-section boom.



Model 14100H — Equipped with a 9,40 m - 30,49 m (30 ft 10 in - 100 ft) four-section boom. This model can be equipped with a 9,15 m (30 ft) single-section jib or a 9,15 m - 16,46 m (30 ft - 54 ft) two-section jib. Maximum tip height with 9,15 m (30 ft) jib is 41,77 m (137 ft), while maximum tip height with 9,15 m - 16,46 m (30 ft - 54 ft) jib is 49,08 m (161 ft).

9,40 m - 30,49 m (30 ft 10 in - 100 ft) four-section boom



14FJ30M 9,15 m (30 ft) single-section jib

9,40 m - 30,49 m (30 ft 10 in - 100 ft) four-section boom



14FJ54M 9,15 m - 16,46 m (30 ft - 54 ft) two-section jib

Model 14127H — Equipped with a 9,63 m - 38,72 m (31 ft 7 in - 127 ft) five-section boom. This model can be equipped with a 9,15 m (30 ft) single-section jib. Maximum tip height with 9,15 m (30 ft) jib is 50,00 m (164 ft).

9,63 m - 38,72 m (31 ft 7 in - 127 ft) five-section boom



14FJ30M 9,15 m (30 ft) single-section jib

Note: Maximum tip is measured with outriggers/stabilizers fully extended.







PORTLAND OFFICE: 503.283.3111
SEATTLE OFFICE: 206.784.1054
WWW.NESSCAMPBELL.COM

Specifications

1400H winch data

- not deadhead line block against boom tip when extending boom
- at least 3 wraps of loadline on drum at all times.
- only use 5/8 in diameter rotation-resistant cable with 45,400 lb breaking strength on this machine.

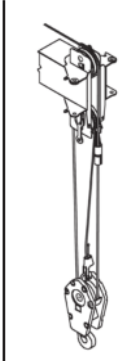
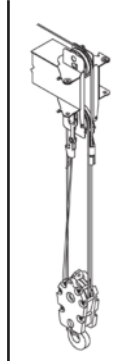
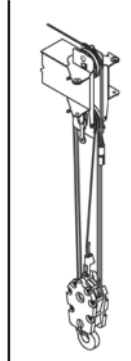
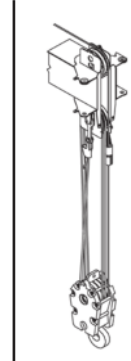
MAXIMUM LENGTH AT MAXIMUM ELEVATION WITH RIGGING SHOWN WITH LOAD BLOCK AT GROUND LEVEL

1 part line	2 part line	3 part line	4 part line	5 part line	6 part line	7 part line	8 part line
							
127 ft boom with 54 ft jib	110 ft	83 ft	64 ft	52 ft	43 ft	36 ft	31 ft

Winch	Cable supplied	Average breaking strength	Lift and speed	Lift and speed	Lift and speed	Lift and speed	Lift and speed	Lift and speed	Lift and speed	Lift and speed
Low speed	5/8" diameter rotation resistant	20 593 kg (45,400 lb)	4082 kg (9000 lb) 52 m/min (170 fpm)	8165 kg (18,000 lb) 26 m/min (85 fpm)	12 247 kg (27,000 lb) 17 m/min (57 fpm)	16 329 kg (36,000 lb) 13 m/min (43 fpm)	20 412 kg (45,000 lb) 10 m/min (34 fpm)	24 494 kg (54,000 lb) 9 m/min (28 fpm)	28 576 kg (63,000 lb) 7 m/min (24 fpm)	29 937 kg (66,000 lb) 6 m/min (21 fpm)
High speed	5/8" diameter rotation resistant	20 593 kg (45,400 lb)	1996 kg (4400 lb) 104 m/min (340 fpm)	3992 kg (8800 lb) 52 m/min (170 fpm)	5987 kg (13,200 lb) 34 m/min (113 fpm)	7983 kg (17,600 lb) 26 m/min (85 fpm)	9979 kg (22,000 lb) 21 m/min (68 fpm)	11 975 kg (26,400 lb) 17 m/min (57 fpm)	13 971 kg (30,800 lb) 15 m/min (49 fpm)	15 967 kg (35,200 lb) 13 m/min (43 fpm)

Winch	Full drum pull
Standard planetary	1996 kg (4400 lb) high speed 4082 kg (9000 lb) low speed

Loadline deduct		
Block type	Rating	Weight
Downhaul weight	4,53 t (5 USt)	82 kg (180 lb)
1-sheave block	13,60 t (15 USt)	170 kg (375 lb)
2-sheave block	22,67 t (25 USt)	290 kg (640 lb)
3-sheave block	31,74 t (35 USt)	395 kg (870 lb)
4-sheave block	32,65 t (36 USt)	440 kg (970 lb)



PORTLAND OFFICE: 503.283.3111
SEATTLE OFFICE: 206.784.1054
WWW.NESSCAMPBELL.COM

Capacities

Series 1469H: 21,03 m (69 ft) boom/full-span outrigger 7,5 m (24 ft 6 in)

Other Series 1400H Load Rating Charts are available. National Crane will send you a chart on request – or you may secure needed load rating information through your nearest National Crane dealer.

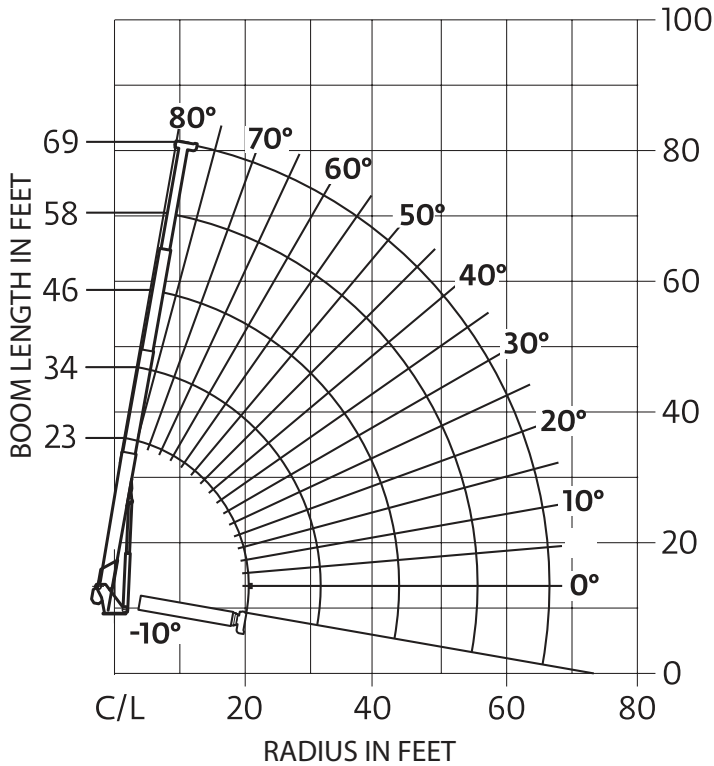

CAUTION:

- Do not operate crane booms, jib extensions, any accessories or loads within 10 ft (3 m) of live power lines or other conductors of electricity.
- Jib and boom capacities shown are maximum for each section.
- Do not exceed capacities at reduced radii.
- Load ratings shown on the appropriate charts are maximum allowable loads with the crane mounted on a factory-approved truck and all outriggers at either full span or at mid span range and set on a firm level surface so that the crane is level and all tires are suspended.
- Always level the crane with the level indicator located on the crane.
- The operator must reduce load to allow for factors such as wind, ground conditions, operating speeds and their effects on freely suspended loads.
- Overloading this crane may cause structural collapse or instability.
- Weights on any accessories attached to the boom or loadline must be deducted from the load chart capacities.
- Do not deadhead lineblock against boom tip when extending boom or winching up.
- Keep at least three wraps of loadline on drum at all times.
- Use only specified cable with this machine.

Load chart

LO ADED RADIUS (ft)	LO ADED BOOM ANGLE (deg)	23 ft BOOM (lb)	LO ADED BOOM ANGLE (deg)	A 34 ft BOOM (lb)	LO ADED BOOM ANGLE (deg)	B 46 ft BOOM (lb)	LO ADED BOOM ANGLE (deg)	C 58 ft BOOM (lb)	LO ADED BOOM ANGLE (deg)	69 ft BOOM (lb)
6	74.5	66,000								
8	69	60,050	76.5	56,300						
10	63	52,050	73	48,350	78	46,100				
12	57	46,000	69.5	42,500	75.5	40,300	79	35,600		
14	50	41,150	65.5	38,000	73	35,850	77	32,550	79.5	25,700
16	42	36,950	61.5	34,400	70	32,350	75	29,500	77.5	23,850
20	15	26,550	52.5	28,950	64.5	27,150	70.5	24,950	74.5	21,200
25			40	21,450	57	21,700	65	20,900	69.5	17,200
30			19	15,450	49	15,750	59.5	15,900	65	15,100
35					39	12,050	53	12,200	60	12,200
40					25.5	9550	46	9650	55	9700
45							38.5	7900	50	7950
50							28.5	6550	43.5	6600
55							11	5500	36.5	5500
60									28	4650
65									16	3950
	0	19,750	0	12,150	0	8350	0	5450	0	3750

*Shaded areas are structurally limited capacities.



PORTLAND OFFICE: 503.283.3111
 SEATTLE OFFICE: 206.784.1054
WWW.NESSCAMPBELL.COM

Capacities

Series 14100H: 30,5 m (100 ft) boom with 9,1 m - 16,45 m (30 ft - 54 ft) jib/full-span outrigger 7,5 m (24 ft 6 in)

Other Series 1400H Load Rating Charts are available. National Crane will send you a chart on request – or you may secure needed load rating information through your nearest National Crane dealer.

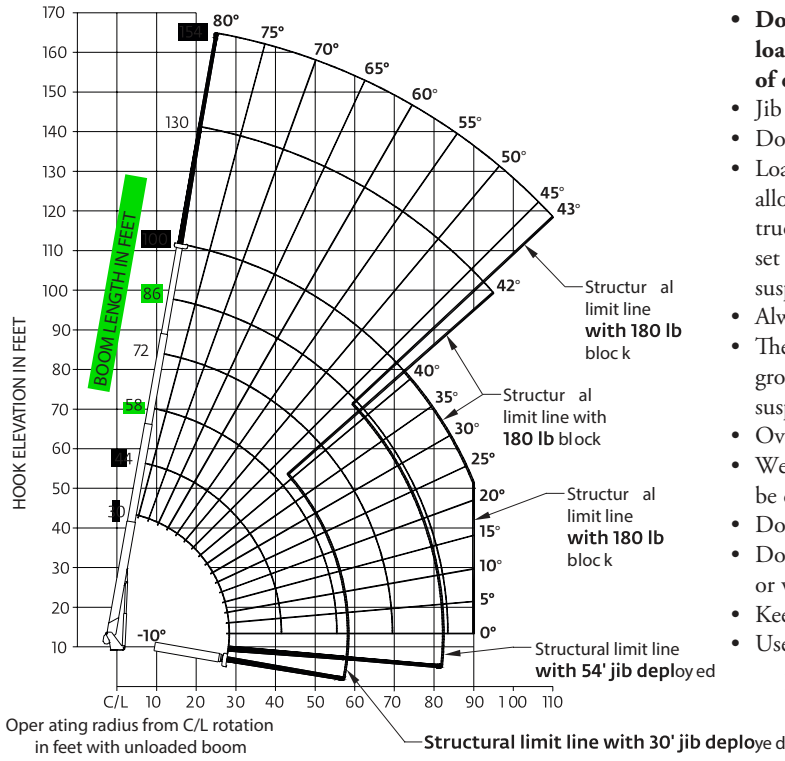

CAUTION:

- Do not operate crane booms, jib extensions, any accessories or loads within 10 ft (3 m) of live power lines or other conductors of electricity.
- Jib and boom capacities shown are maximum for each section.
- Do not exceed capacities at reduced radii.
- Load ratings shown on the appropriate charts are maximum allowable loads with the crane mounted on a factory-approved truck and all outriggers at either full span or at mid span range and set on a firm level surface so that the crane is level and all tires are suspended.
- Always level the crane with the level indicator located on the crane.
- The operator must reduce load to allow for factors such as wind, ground conditions, operating speeds and their effects on freely suspended loads.
- Overloading this crane may cause structural collapse or instability.
- Weights on any accessories attached to the boom or loadline must be deducted from the load chart capacities.
- Do not exceed jib capabilities at any reduced boom lengths.
- Do not deadhead lineblock against boom tip when extending boom or winching up.
- Keep at least three wraps of loadline on drum at all times.
- Use only specified cable with this machine.

NOTE:

- Operate with jib by radius when main boom is fully extended. If necessary increase boom angle to maintain loaded radius.
- Operate with jib by boom angle when main boom is not fully extended. Do not exceed rated jib capacities at any reduced boom lengths.

Load chart

LOAD RADIUS (ft)	LOADED BOOM ANGLE	30 ft BOOM (lb)	LOADED BOOM ANGLE	A 44 ft BOOM (lb)	LOADED BOOM ANGLE	B 58 ft BOOM (lb)	LOADED BOOM ANGLE	C 72 ft BOOM (lb)	LOADED BOOM ANGLE	D 86 ft BOOM (lb)	LOADED BOOM ANGLE	100 ft BOOM (lb)	LOAD RADIUS (ft)	LOADED BOOM ANGLE	30 ft JIB (lb)	LOADED BOOM ANGLE	54 ft JIB (lb)	
6	79.1	66,000											30	78.4	5500			
8	74.9	49,200											35	76.5	5450	78.5	2650	
10	70.6	42,200	77.2	37,900									40	74.6	5400	76.9	2600	
12	66.3	38,600	74.9	33,400	79.2	29,550							45	72.4	5100	75.2	2500	
14	61.7	34,200	72.1	29,400	77.1	26,550	80	23,050					50	70.1	4600	73.4	2400	
16	56.8	30,350	69.2	26,900	75.1	24,550	78.6	21,050					55	67.8	4250	71.6	2300	
20	46	23,550	63.3	21,400	70.8	19,250	75.3	18,050	78.4	16,800	80	11,600	60	65.5	3900	69.8	2200	
25	27.4	16,700	55.2	17,400	65.3	16,050	71	14,650	74.9	13,700	77.3	10,950	65	62.7	3200	67.9	2100	
30			46.1	13,900	59.5	13,550	66.7	12,550	71.3	11,450	74.5	10,550	70	59.9	2600	66	2000	
35			35	10,350	53.1	10,650	61.9	10,550	67.7	9900	71.8	9150	75	57.1	2050	64	1850	
40			20	8000	46.8	8250	57.6	8400	64.3	8550	68.4	8050	80	54.1	1650	61.8	1750	
45					38.8	6500	52.4	6650	60.1	6750	65.3	6850	85	51.1	1250	59.6	1600	
50					29	5150	46.7	5300	55.9	5400	61.9	5500	90	47.9	950	57.4	1500	
55					12.3	4150	40.4	4250	51.5	4400	58.3	4450	95	44.5	650	54.8	1200	
60							33.2	3400	46.7	3550	54.6	3600	100			52.2	950	
65							23.8	2750	41.5	2850	50.7	2900	105			49.4	700	
70										35.7	2250	46.6	2300	110			46.6	500
75										28.8	1750	42.2	1800					
80										19.6	1350	37.3	1400					
85												31.8	1050					
90												25.2	700					
	0	11,400	0	7300	0	4000	0	1850	0	900								
		ADD TO CAPACITIES WHEN NO JIB STOWED (lb)																
		800		600		450		350		300		250						

*Shaded areas are structurally limited capacities.



PORTLAND OFFICE: 503.283.3111
SEATTLE OFFICE: 206.784.1054
WWW.NESSCAMPBELL.COM

Dimensions

	Retracted	Extended	G	wet/wt*
Series	Length	Length	cm (in)	kg (lb)
1469H	23 ft	69 ft	153 (60.2)	10 182 (22,448)
14100H	30 ft 10 in	100 ft	210 (82.7)	11 626 (25,631)
14127H	31 ft 7 in	127 ft	230 (90.4)	12 869 (28,371)

*Wet weight includes boom with winch, loadline, 180 lb downhaul weight, frame, turret, complete console, hoses, mounting hardware, outriggers, platforms, lift cylinder, and torsion box for 22 ft bed.

Dimensions are in mm (in) unless otherwise specified.

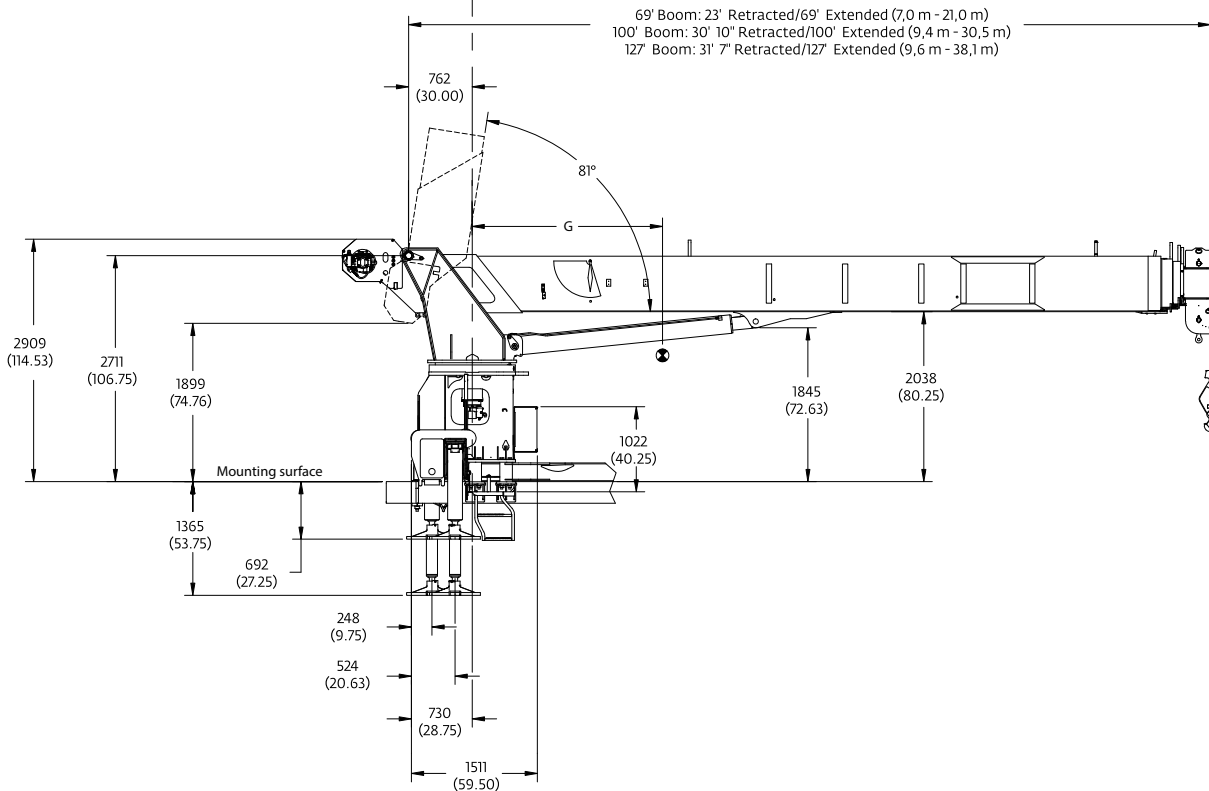
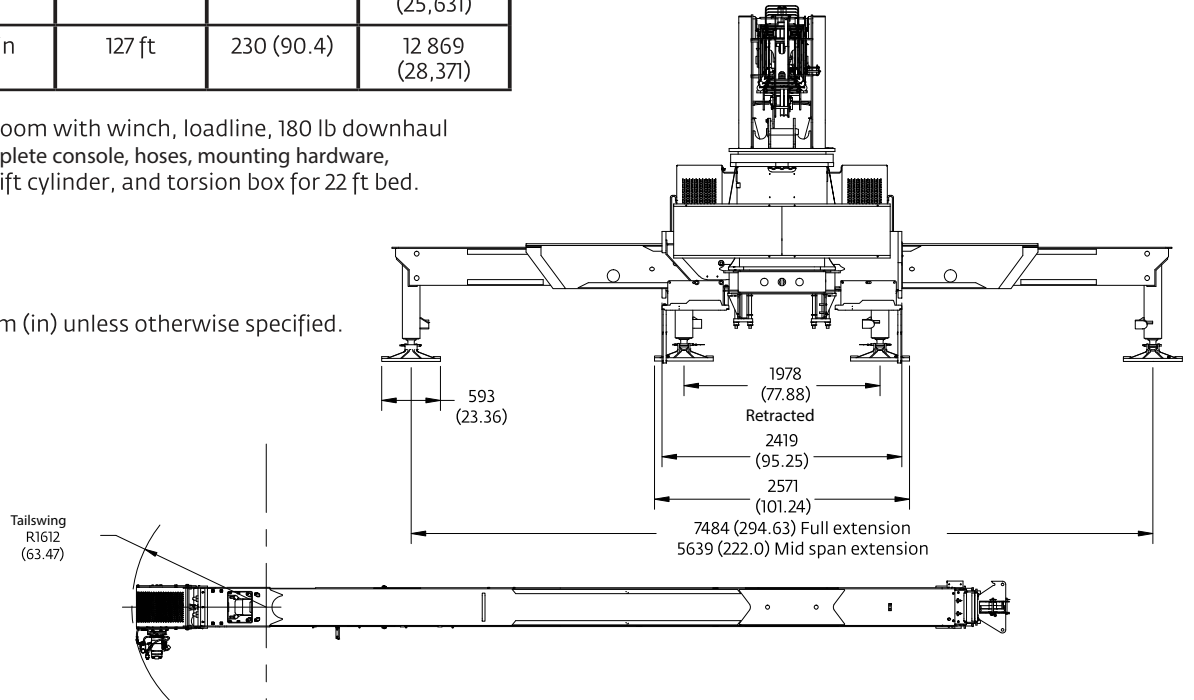

PORTLAND OFFICE: 503.283.3111
 SEATTLE OFFICE: 206.784.1054
WWW.NESSCAMPBELL.COM